

PARTS LIST				
ITEM	QTY	PART NUMBER	PARTS LIST	DESCRIPTION
1	2	69502825		
2	1	HINGE_LOWER_TEST_MOD		
3	1	HINGE_UPPER_TEST		
4	1	MA01-1001		
5	1	MB34-1001	Emblem - Momentum	
6	1	MB34-1015		
7	1	MB34-1115-N	PRD HIGH PRESSURE TUBE	
8	1	MB34-1116-N		
9	1	MB34-1117-N		
10	1	MB34-1118-N	PRD HIGH PRESSURE TUBE	
11	1	MB34-1119-N		
12	1	MB34-1120-N		
13	1	MC31-1007L-R0339		
14	1	MC31-1008L-R0074		
15	1	MC31-1009-R0073		
16	1	MC31-1028L-001		
17	1	MC32-1010-R0263		
18	1	MC32-1104-N		
19	1	MC32-1105-N	PRD HIGH PRESSURE TUBE	
20	1	MD04-1000	BUSHING-NECK BLOCK	
21	2	MD18-1001		
22	1	MD18-1002		
23	1	MD20-1002	CLAMP PAIR-SINGLE TUBE 1/2" OD	
24	1	MD20-1007	CLAMP - TUBE, DOUBLE, 1/2"	
25	1	MD23-1006	3/16 x 48 x 120, A572, 58KSI MIN	
26	1	MD23-1007RL	48 x 120 x 10GA A606 Type 4	
27	1	MD23-1010RL	3/16 x 48 x 120, A572, 58KSI MIN	
28	1	MD23-1107-N	48 x 120 x 11GA ASTM A366 CROCC	
29	1	MD23-1122-N	3/16 x 48 x 120, A572, 58KSI MIN	
30	5	MD32-1001-R0283		
31	4	ME04-1006-R0064	ALUMINUM 6005A-T61	
32	2	ME04-1035		
33	1	ME04-1040L	Domex 100 XF 1/4" thick	
34	1	ME04-1040R		
35	29	ME04-1058	FLOATING NECK BLOCK	
36	1	ME04-1060	Domex 100 XF 1/4" thick	
37	2	ME29-1001-R0256		
38	2	ME29-1004-R0249	ASSEMBLY - ISOLATOR BRACKET	
39	1	MF13-1000	RECEPTACLE - HEAVY DUTY FILL	
40	1	MF13-1001	RECEPTACLE - NGV1 FILL	
41	1	MF17-1004	FITTING - UNION - STRAIGHT - #6 ORING X # 6 ORING (9/16"-18)	
42	1	MF17-1007	DEFUEL NIPPLE - 316SS - 6 SAE CNS	
43	2	MF17-1008	FITTING - BULKHEAD, BRASS 3/8" HOSE BARB X 5/8" HOSE BARB	
44	1	MF17-1013	ELBOW - 90° 1/2" STANDARD O-RING X 1/2" ORFS (O-RING FACE SEAL)	
45	1	MF17-1014	ADAPTER - STRAIGHT - #6 ORING BOSS X #8 ORFS	
46	7	MF17-1015	ADAPTER - STRAIGHT - #8 ORING BOSS X #8 ORFS	
47	2	MF17-1016	PLUG - #8 ORING BOSS	
48	1	MF17-1018	ADAPTER - BULKHEAD - STRAIGHT - #6 ORFS X #6 ORING BOSS	
49	1	MF17-1019	ADAPTER - 90° ELBOW - #6 ORING BOSS X #6 ORFS	
50	1	MF17-1020	VALVE - 2 WAY, -6 ORFS	
51	1	MF17-1021	VALVE - 3 WAY, -6 ORFS	
52	4	MF17-1024	YORK PRD SPACER	
53	1	MF17-1025	FITTING - TEE - SWIVEL RUN -6 FEMALE SWIVEL X-6X-6 ORFS	
54	3	MF17-1029	NUT 3/8" ORFS	
55	2	MF17-1102-N	BULKHEAD-UNION, 1/2" ORFS	
56	1	MF17-1104-N	TEE-BRANCH SWIVEL NUT, 3/8" ORFS X 3/8" ORFS X 3/8" ORFS SWIVEL	
57	1	MF17-1106-N	PRD HIGH PRESSURE TUBE	
58	1	MF17-1141-N	ADAPTER - STRAIGHT #6 (3/8") ORFS X #6 (3/8") TUBE	
59	1	MF17-1142-N	6-4 CSOLO-SS	
60	3	MF17-1143-N	FITTING - BULKHEAD, 90° ELBOW - #8 ORFS X #8 ORFS	
61	1	MF17-1145-N		

PARTS LIST				
ITEM	QTY	PART NUMBER	PARTS LIST	DESCRIPTION
62	1	MF17-1146-N	ADAPTER - 90° ELBOW - #6 ORING BOSS X #8 ORFS	
63	3	MF17-1148-N	FITTING - 90° ELBOW-8 ORFS MALE X -8 ORFS FEMALE SWIVEL	
64	1	MF17-1628	FITTING - UNION, 90° ELBOW, TUBE, 3/8" TUBE OD	
65	1	MF18-1000	CAP - VENT, HEAVY DUTY, 0.5"	
66	1	MG25-1100-N		
67	1	MG25-1101-N	PRD VENT TUBE	
68	60	MH27-1001-004-20-075-YZ-008-FL	1/4"-20 X .75" HEX FLANGE BOLT, GR8 YZ	
69	42	MH27-1001-004-20-100-YZ-008-FL	1/4"-20 X 1.00" HEX FLANGE BOLT, GR8 YZ	
70	34	MH27-1001-004-20-100-YZ-XXX-FH	SCREW - 1/4"-20 x 1" Phillips Drive Flat Head, YZ	
71	2	MH27-1001-004-20-175-YZ-008-HH	Bolt-1/4-20 x 1.75", Yellow Zinc Hex Head Grade 8	
72	6	MH27-1001-004-20-225-YZ-008-HH	HX CP PL USS 1/4x2-1/4	
73	12	MH27-1001-004-20-275-YZ-008-HH	BOLT - 1/4-20 x 2.75, YZ, GR8, HH	
74	116	MH27-1001-006-16-125-YZ-008-HH	HX CP PL USS 3/8x1-1/4	
75	28	MH27-1001-006-16-200-YZ-008-HH	3/8"-16 X 2 HEX HEAD BOLT	
76	6	MH27-1001-M06-32-075-SS-188-PH	Bolt-Pan Head,6-32x3/4 S/S	
77	12	MH27-1004-M06-FL-SS-188	#6 F/W S/S, .149x.375	
78	31	MH27-1010	ANGLE LOWER SUPPORT 70 DGE BOC	
79	40	MH27-1014	1/4-20 Short U Nut	
80	36	MH27-1017	U-NUT 1/4-20	
81	80	MH27-1020	3/16"-10 BUTTON HEAD HUCK	
82	80	MH27-1021	3/16" MEG COLLAR	
83	65	MH27-1023	1/4"-20 X 3/4" SS FLAT HEAD PHILLIPS MACHINE SCREW	
84	1	MH30-1001-R0277		
85	1	MH30-1002-R0274		
86	2	MK08-1000-01	ACCESSORIES - HINGE, BUTT	
87	1	MP10-1000	SWIVEL NUT BRANCH TEE, ORFS	
88	1	MP10-1001	FLIM - (FUEL LEVEL INDICATOR MODULE)	
89	2	MP15-1000	RELAY, MINI (SPDT) CHANGE-OVER W/BRKT AND RESISTOR	
90	1	MP15-1004		
91	1	MS15-1002	REGULATOR-CNG, PARKER FMB8 VERIFLO LH CONFIGURATION	
92	1	MS12-1002	ANGLE TANK SUPPORT BOTTOM 70 DGE BOC	
93	1	MS15-1001	VALVE CARTRIDGE CHECK	
94	5	MS19-1600	VALVE-TANK, OMB BETA NEW PLUS	
95	1	MT15-1001	MUFFLER - STEEL 1/4" NPT - 105 SCFM 1-3/4 HEIGHT	
96	1	MT21-1122-N		
97	1	MT21-1123-N		
98	1	MT21-1123-N_modified		
99	1	MT21-1124-N		
100	1	MT21-1125-N		
101	1	MT21-1126-N		
102	2	MT21-1127-N		
103	2	MT21-1129-N		
104	1	MT21-1130-N		
105	1	MT21-1131-N		
106	1	MT21-1132-N		
107	1	MT21-1133-N		
108	1	MT21-1136-N		
109	1	MT21-1137-N		
110	2	MT21-1138-N		
111	1	MT21-1151-N		
112	1	MT21-1186-YELLOW	TUBING 3/8" - DEFUEL VALVE TO MANUAL SHUTOFF VALVE	
113	1	MT21-1187-N		
114	1	MT21-1190-N	3/8" PANEL SPACER	
115	1	MT22-1001_V1		
116	1	MT22-1001_V2	PRD VENT TUBE	
117	2	MV29-1000		
118	2	MV30-1001		
119	1	PTF01-RCNG-0287-AA_0010003_DOOR_C	AP, REAR, LH, MODEL SOLIDS, revised1	
120	1	SS-4PST8	PURGE VALVE W/ SS BALL	
121	1	SS_G83XP56_F4_600_1-4		
122	2	VALVE HANDLE-RED	VALVE - 3 WAY, -6 ORFS	

CONFIDENTIAL AND TRADE SECRET INFORMATION OF RUSH ENTERPRISES, INC.

This document and the information in it is confidential, proprietary and trade secret information of Rush Enterprises, Inc. and its subsidiaries ("Rush"). It contains information intended only for the person to whom it is transmitted and may not be disclosed to any third party, in whole or in part, or used to manufacture anything shown or referred to herein, without Rush's express, written permission. This document must be returned to Rush on request.

Any form of reproduction, dissemination, copying, disclosure, modification, distribution and or publication of this document and the information contained herein is strictly prohibited.

This notice must appear on any complete or partial reproduction of this document or the information contained herein.

Copyright © 2016 Rush Enterprises, Inc. All rights reserved.

ALL DIMENSION TOLERANCES UNLESS NOTED
ONE PLACE .X ±.06
TWO PLACES .XX ±.03
THREE PLACES .XXX ±.010
FOUR PLACES .XXXX ±.0010
ANGLES ±1.0°
ALL MACHINED SURFACES TO BE 250 RMS UNLESS NOTED.

NOTES:

- FOR INFORMATION NOT CONTAINED IN THIS PRINT REFERENCE THE MATH DATA FOR THIS PART (601-450000-110000)
- ALL DIMENSIONS ARE IN INCHES
- PART NUMBER, REV LEVEL, AND SUPPLIER CODE REQUIRED ON ALL PARTS. REFER TO DRAWING FOR SPECIFIC LOCATION, WHERE APPLICABLE. ETCH, STAMP, OR OTHERWISE PERMANENTLY ATTACH REQUIRED INFORMATION ON LARGER PARTS. PERMANENT MARKINGS SHALL BE PLACED IN SUCH A WAY THAT THEY ARE VISIBLE AFTER PART IS COATED OR PAINTED. SMALLER PARTS SHOULD HAVE THE INFORMATION ATTACHED BY THE BEST METHOD POSSIBLE. ALTERNATE MEANS OF ATTACHING INFORMATION MUST BE APPROVED.

DO NOT SCALE THIS PRINT

DRAWN	10/15/2018	MOMENTUM FUEL TECHNOLOGIES 1051 Republic Drive, Suite 200 Roanoke, TX 76262	
EK CHECKED		45 DGE SM	
QA		SIZE: D DWG NO: 601-450000-110000 REV:	
MFG		SCALE: SHEET 1 OF 9	
APPROVED			
Part Mass			

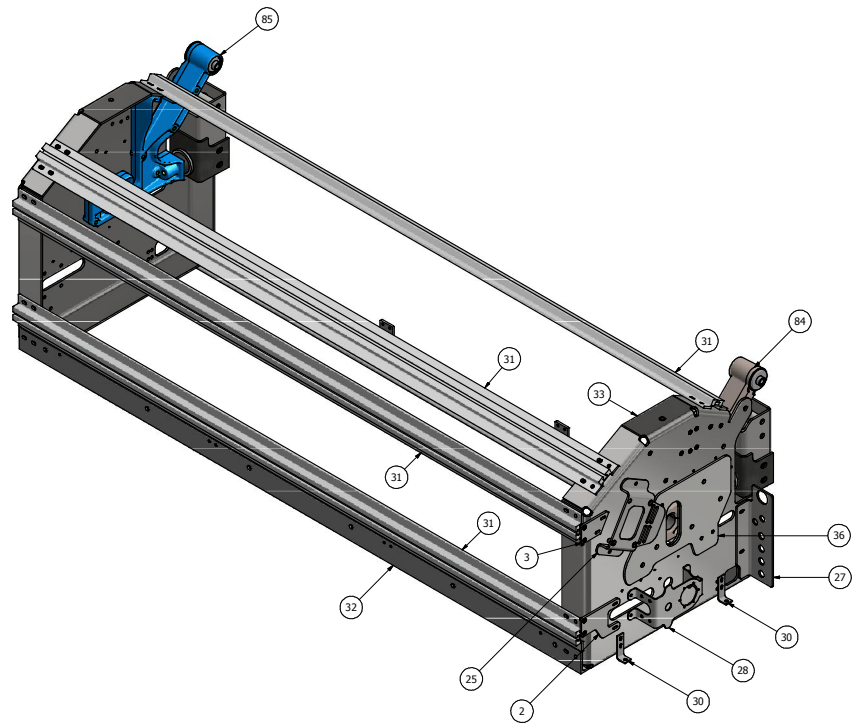

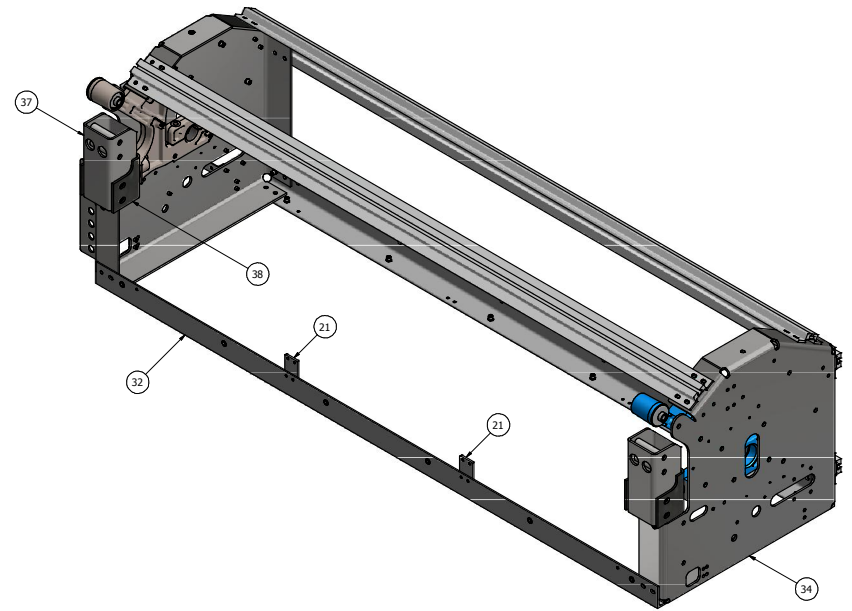

FRONT VIEW



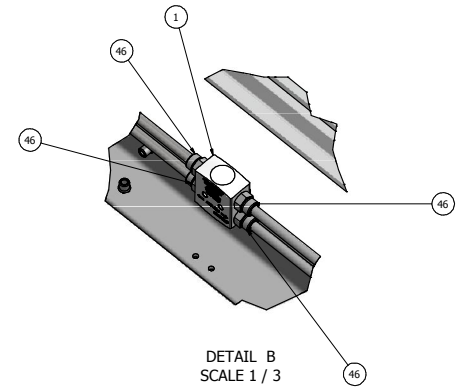
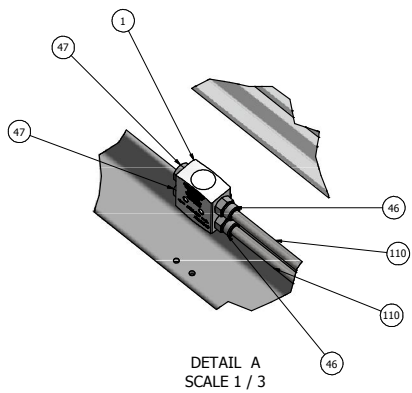
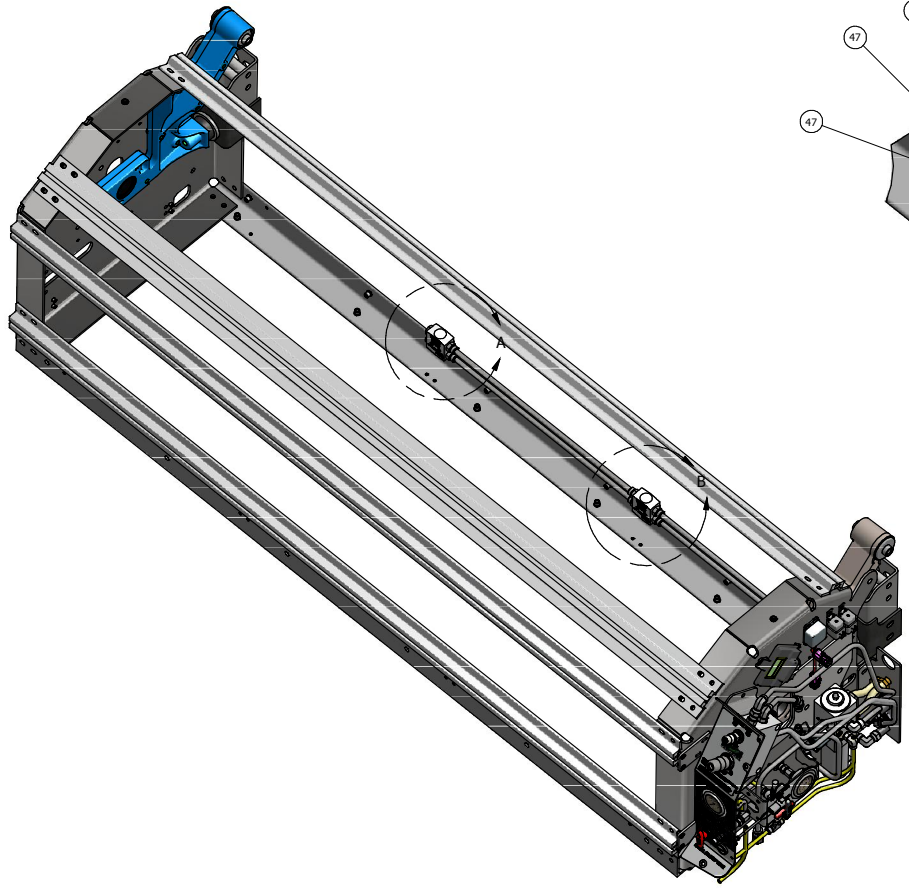

BACK VIEW

DRAWN	10/15/2018	 MOMENTUM FUEL TECHNOLOGIES 1051 Republic Drive, Suite 200 Roanoke, TX 76262	
CHECKED		TITLE	
QA		45 DGE SM	
MFG		SIZE	DWG NO
APPROVED		D	601-450000-110000
Part Mass		SCALE	REV
N/A			1

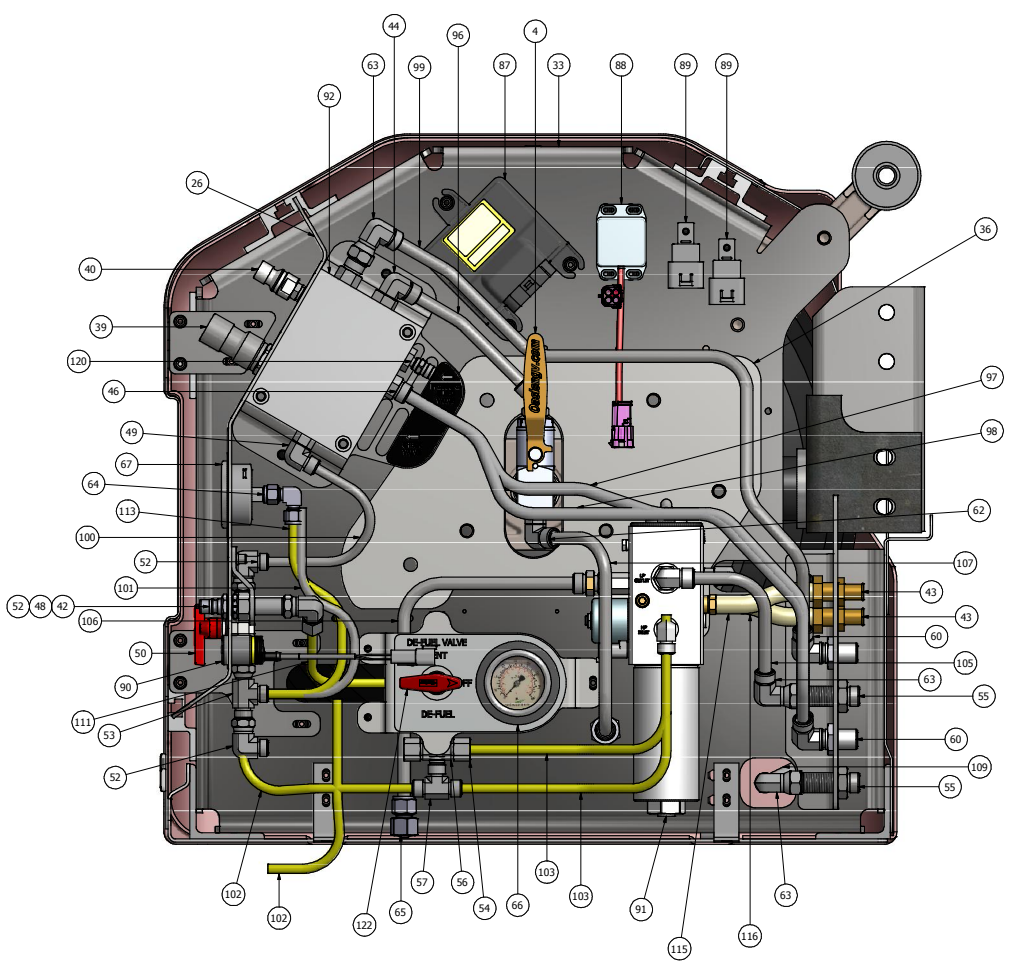
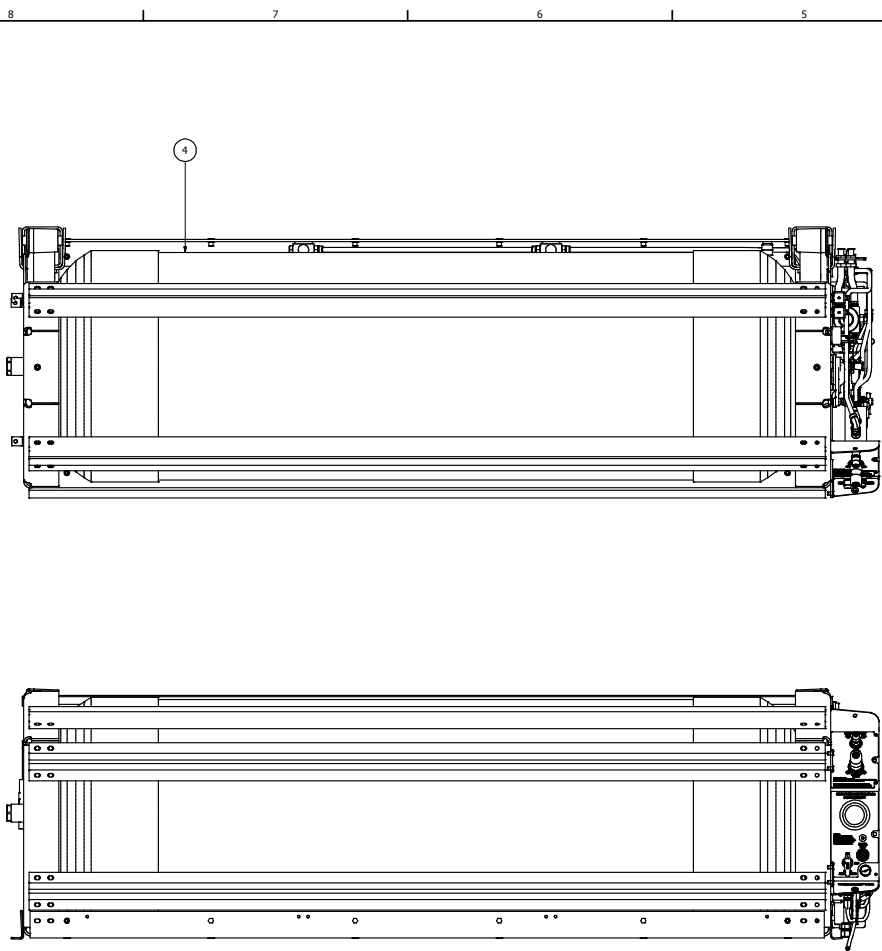

DRAWN	10/15/2018	 MOMENTUM FUEL TECHNOLOGIES 1051 Republic Drive, Suite 200 Roanoke, TX 76262	
CHECKED		TITLE	
QA		45 DGE SM	
MFG			
APPROVED			
Part Mass		SIZE	DWG NO
N/A		D	601-450000-110000
		SCALE	SHEET 3 OF 9



DRAWN	EK	10/15/2018	 MOMENTUM FUEL TECHNOLOGIES 1051 Republic Drive, Suite 200 Roanoke, TX 76262	
CHECKED	QA		TITLE	
MFG			45 DGE SM	
APPROVED			SIZE	DWG NO
Part Mass	N/A		D	601-450000-110000
			SCALE	SHEET 4 OF 9

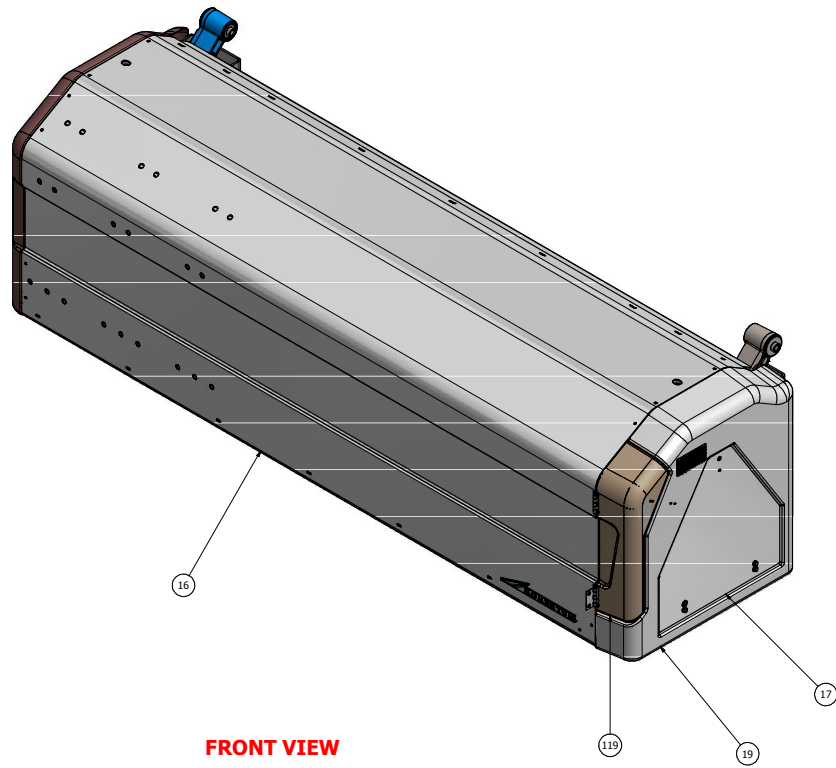

FRONT VIEW

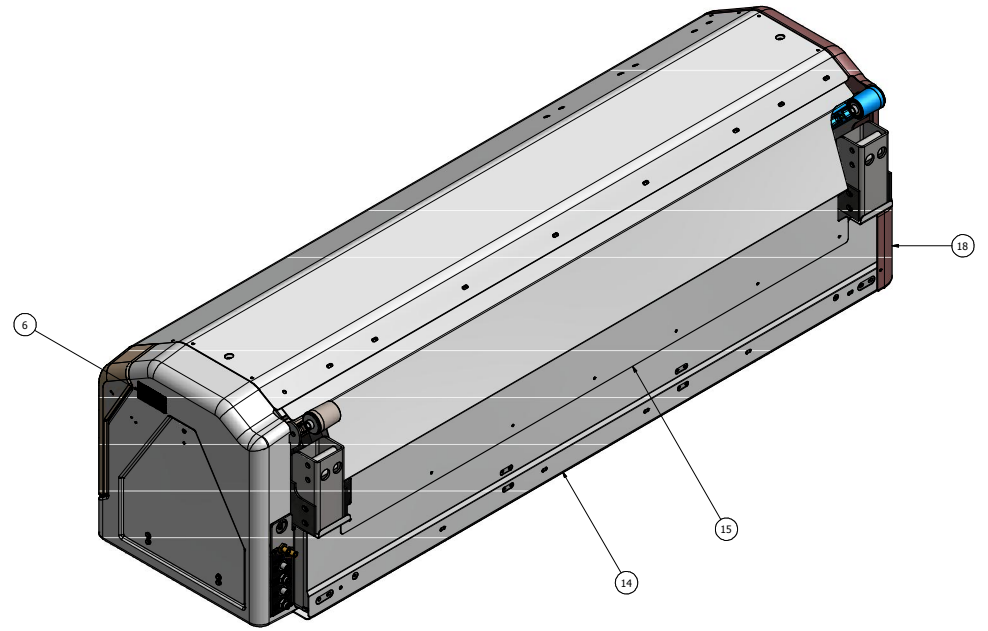

BACK VIEW

DRAWN	10/15/2018	 MOMENTUM FUEL TECHNOLOGIES 1051 Republic Drive, Suite 200 Roanoke, TX 76262	
CHECKED		TITLE	
QA		45 DGE SM	
MFG		SIZE	DWG NO
APPROVED		D	601-450000-110000
Part Mass		SCALE	REV
N/A			1

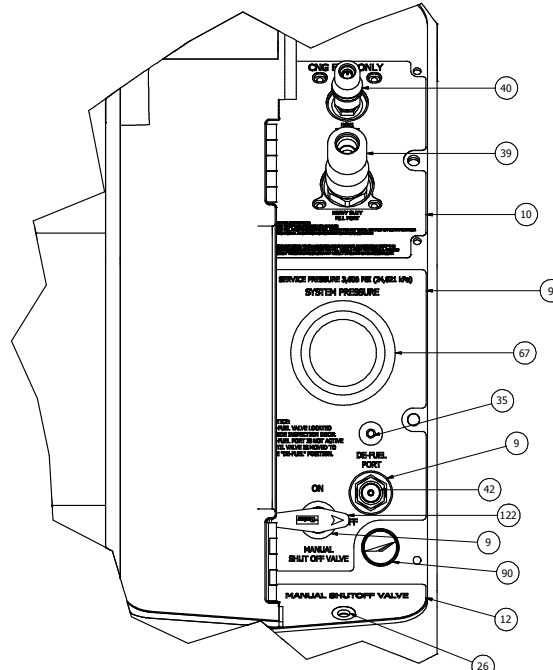
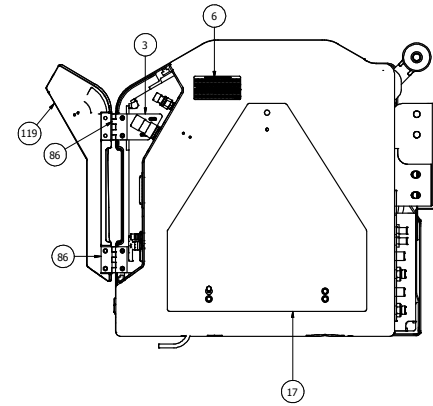
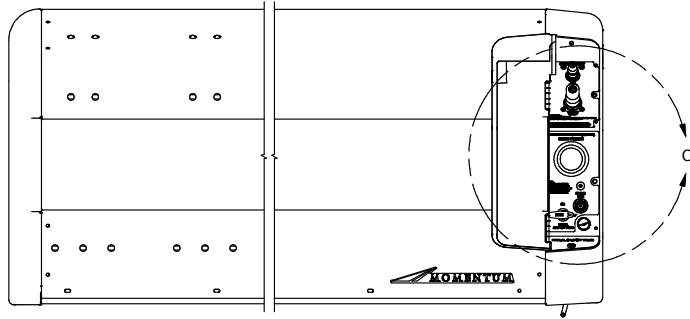

DETAIL C
SCALE 1/2

DRAWN	10/15/2018	 MOMENTUM FUEL TECHNOLOGIES 1051 Republic Drive, Suite 200 Roanoke, TX 76262	
CHECKED		TITLE	
QA		45 DGE SM	
MFG		SIZE	DWG NO
APPROVED		D	601-450000-110000
Part Mass		SCALE	REV
N/A			1

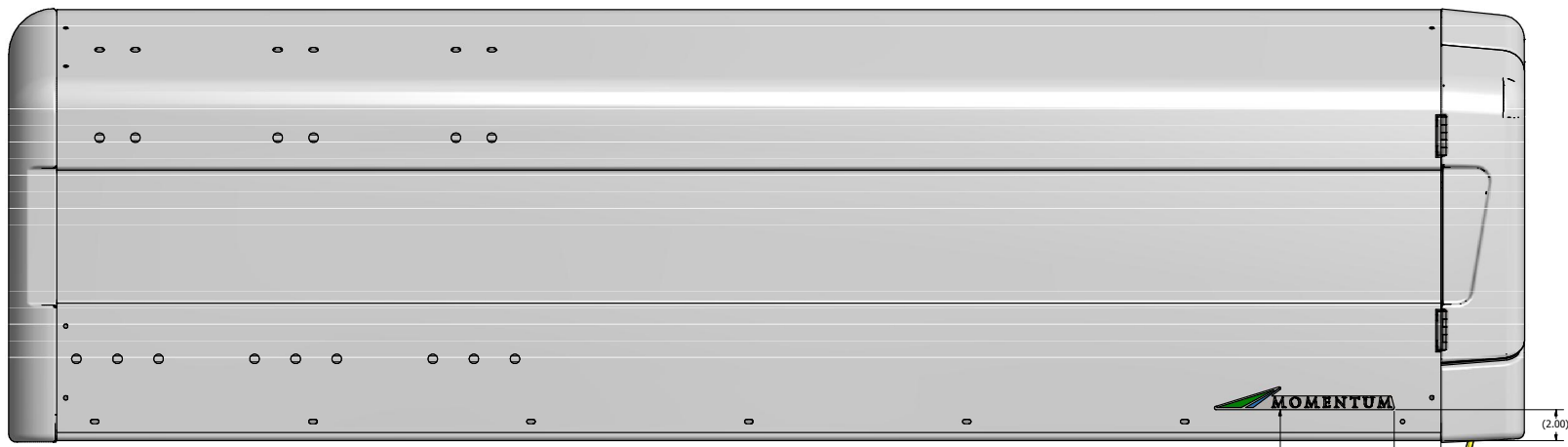

DRAWN	10/15/2018	 MOMENTUM FUEL TECHNOLOGIES 1051 Republic Drive, Suite 200 Roanoke, TX 76262	
CHECKED		TITLE	
QA		45 DGE SM	
MFG			
APPROVED			
Part Mass		SIZE	DWG NO
N/A		D	601-450000-110000
		SCALE	REV
			1

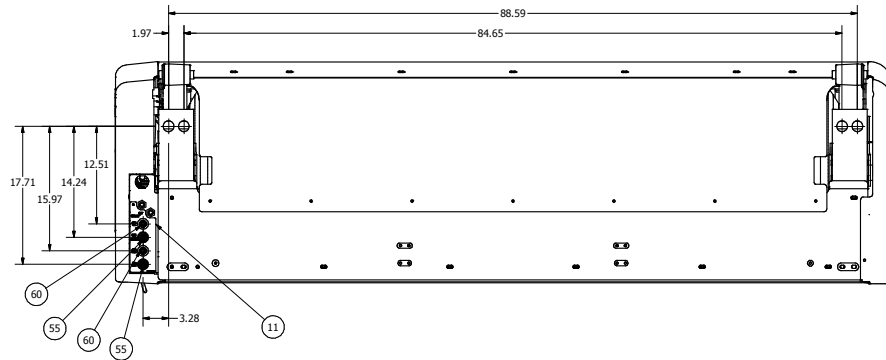
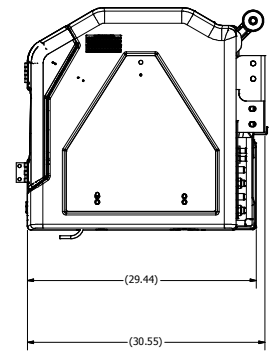
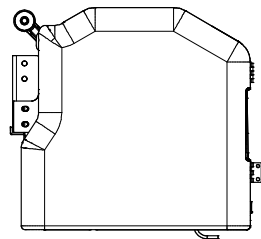
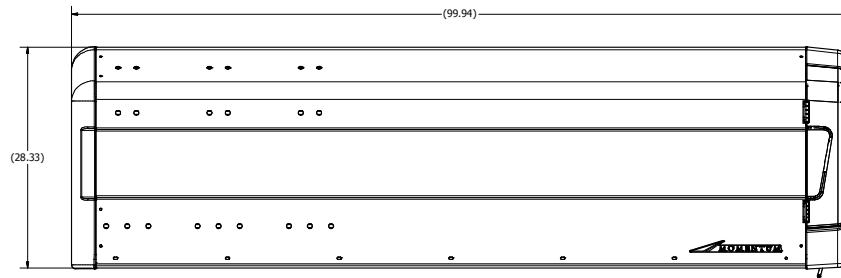
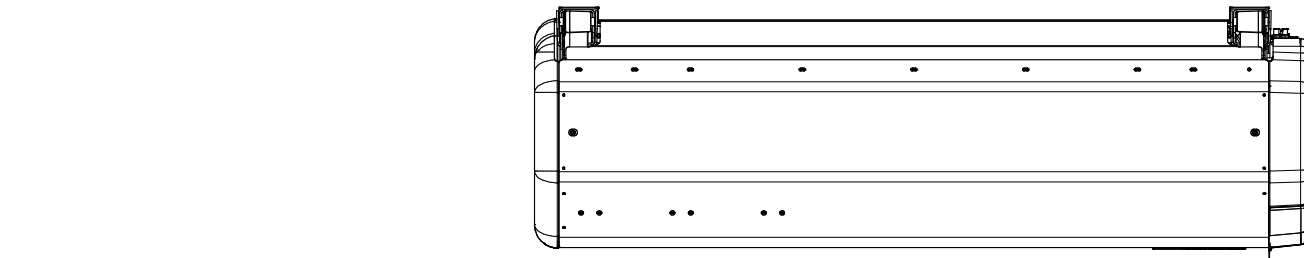

NOTES:

- 1) FOR INFORMATION NOT CONTAINED IN THIS PRINT REFERENCE THE MATH DATA FOR THIS PART (601-450000-110000)
- 2) ALL DIMENSIONS ARE IN INCHES
- 3) FULL SYSTEM WEIGHT w/STEPS AND ALL MOUNTING HARDWARE: 784 LBS

CONFIDENTIAL AND TRADE SECRET INFORMATION OF NATURAL GAS FUEL SYSTEMS, INC. dba MOMENTUM FUEL TECHNOLOGIES

This document and the information in it is confidential, proprietary and trade secret information of Natural Gas Fuel Systems, Inc. dba Momentum Fuel Technologies on behalf of itself and its subsidiaries and affiliates ("Momentum"). It contains information intended only for the person to whom it is transmitted and may not be disclosed to any third party, in whole or in part, or used to manufacture anything shown or referred to herein, without Momentum's express, written permission. This document must be returned to Momentum on request.

Any form of reproduction, dissemination, copying, disclosure, modification, distribution, and or publication of this document and the information contained herein is strictly prohibited.

This notice must appear on any complete or partial reproduction of this document or the information contained herein.

Copyright © 2017 Natural Gas Fuel Systems, Inc. dba Momentum Fuel Technologies. All rights reserved.

ALL DIMENSION TOLERANCES UNLESS NOTED
 ONE PLACE .X ±.06
 TWO PLACES .XX ±.03
 THREE PLACES .XXX ±.010
 FOUR PLACES .XXXX ±.0010
 ANGLES ±1.0°
 ALL MACHINED SURFACES TO BE 250 RMS UNLESS NOTED.

DRAWN	10/15/2018	MOMENTUM FUEL TECHNOLOGIES 1051 Republic Drive, Suite 200 Roanoke, TX 76262	
CHECKED		TITLE	
QA		45 DGE SM	
MFG		SIZE	DWG NO
APPROVED		D	601-450000-110000
Part Mass		SCALE	REV
N/A			1

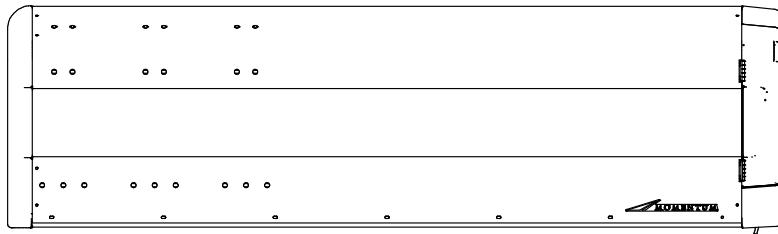

Without Steps

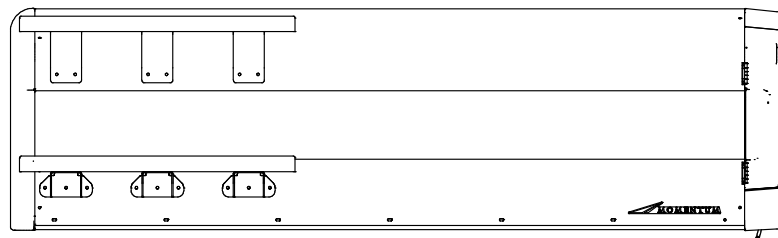
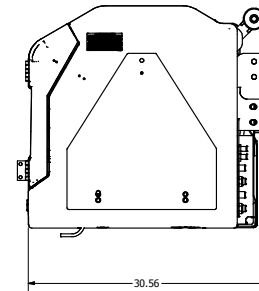

With Steps

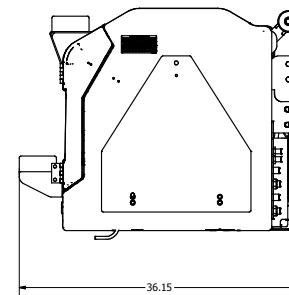

NOTES:

- 1) FOR INFORMATION NOT CONTAINED IN THIS PRINT REFERENCE THE MATH DATA FOR THIS PART (601-450000-110000 WITH STEPS)
- 2) ALL DIMENSIONS ARE IN INCHES
- 3) FULL SYSTEM WEIGHT w/STEPS AND ALL MOUNTING HARDWARE: 784 LBS

CONFIDENTIAL AND TRADE SECRET INFORMATION OF NATURAL GAS FUEL SYSTEMS, INC. dba MOMENTUM FUEL TECHNOLOGIES
 This document and the information in it is confidential, proprietary and trade secret information of Natural Gas Fuel Systems, Inc. dba Momentum Fuel Technologies on behalf of itself and its subsidiaries and affiliates ("Momentum"). It contains information intended only for the person to whom it is transmitted and may not be disclosed to any third party, in whole or in part, or used to manufacture anything shown or referred to herein, without Momentum's express, written permission. This document must be returned to Momentum on request.

Any form of reproduction, dissemination, copying, disclosure, modification, distribution, and or publication of this document and the information contained herein is strictly prohibited.

This notice must appear on any complete or partial reproduction of this document or the information contained herein.

Copyright © 2017 Natural Gas Fuel Systems, Inc. dba Momentum Fuel Technologies. All rights reserved.

ALL DIMENSION TOLERANCES UNLESS NOTED
 ONE PLACE .X ±.06
 TWO PLACES .XX ±.03
 THREE PLACES .XXX ±.010
 FOUR PLACES .XXXX ±.0010
 ANGLES .XXXX ±1.0°
 ALL MACHINED SURFACES TO BE 250 RMS UNLESS NOTED.

DRAWN	10/15/2018	MOMENTUM FUEL TECHNOLOGIES 1051 Republic Drive, Suite 200 Roanoke, TX 76262	
EK		TITLE	
CHECKED		45 DGE SM	
QA		SIZE	DWG NO
MFG		D	601-450000-110000
APPROVED		SCALE	REV
Part Mass	N/A		
			SHEET 9 OF 9