

FRONT VIEW

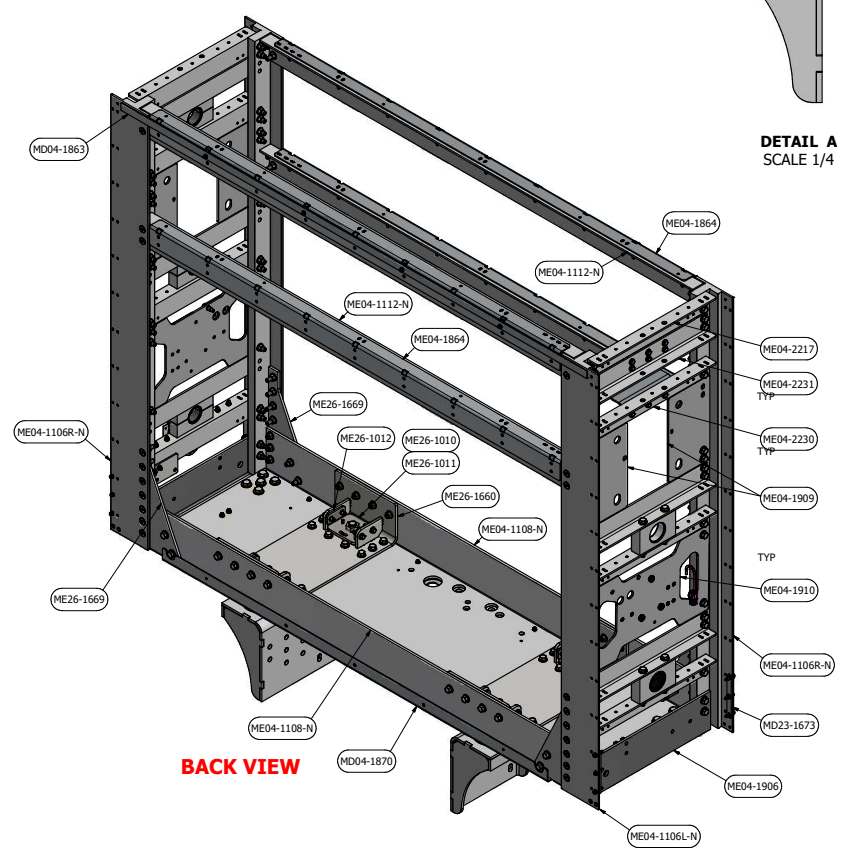

BACK VIEW

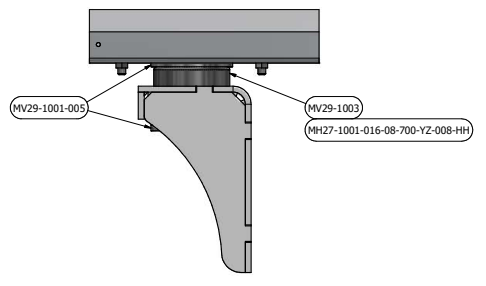

**DETAIL A
SCALE 1/4**

DRAWN KSA	4/16/2020	MOMENTUM FUEL TECHNOLOGIES	
CHECKED		1051 Republic Drive, Suite 200 Roanoke, TX 76262	
QA		TITLE	
MFG		BOC, 80 DGE, (2) LUXFER 22X86 TANKS, (1) LUXFER 16X81 TANK, 500KB AUTOCAR ACX, AUX FILL	
APPROVED		SIZE D	DWG NO 500-008000-00110014-500KB-AUTOCAR ACX
Part Mass N/A		SCALE	REV
			SHEET 2 OF 8

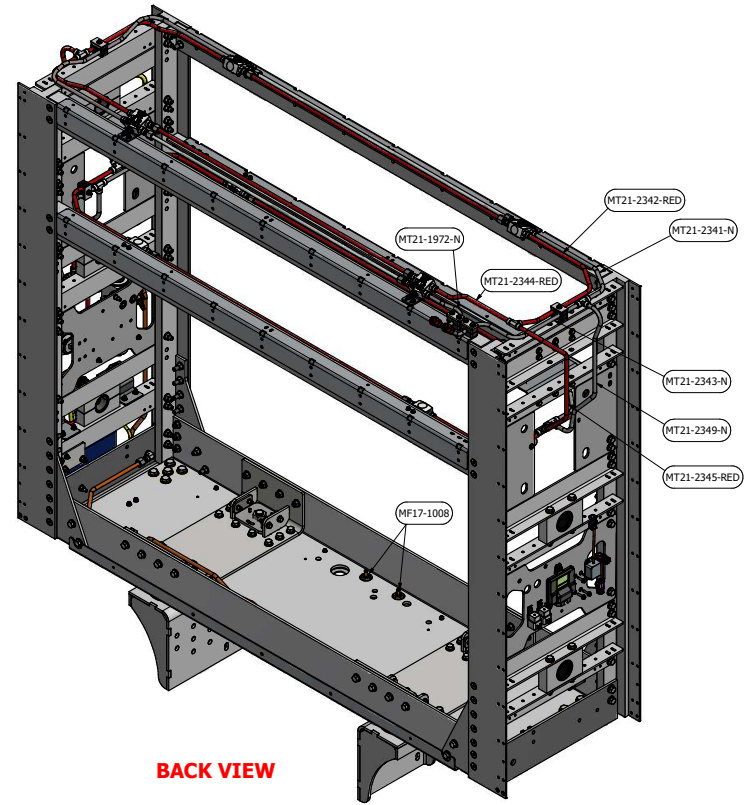
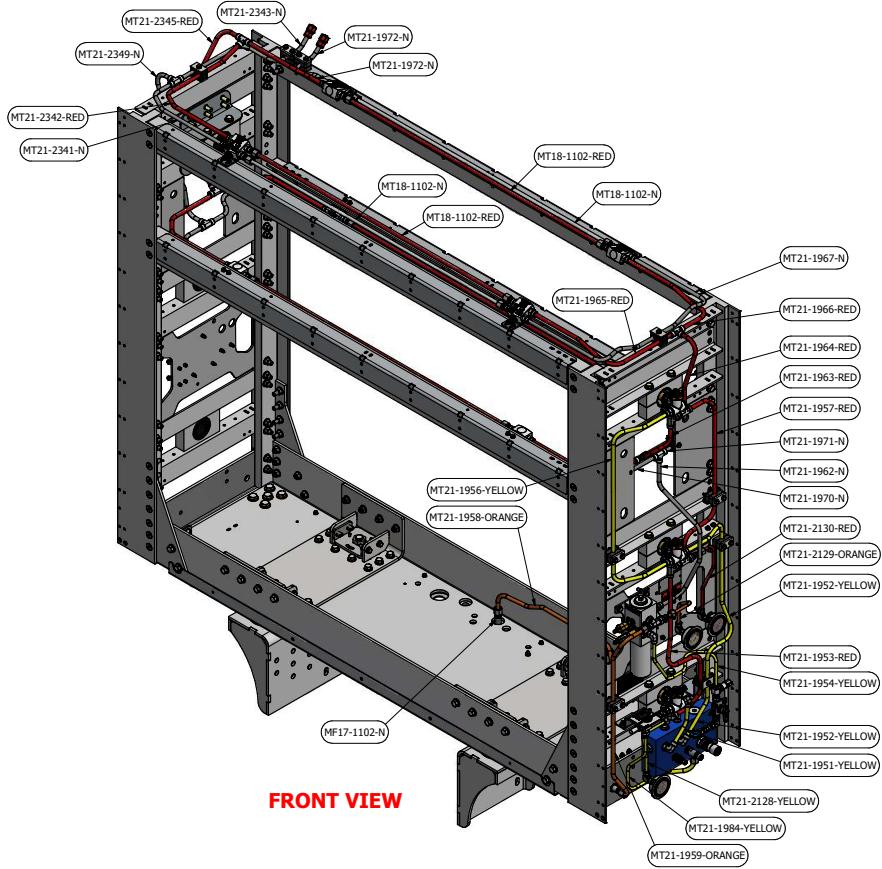

PRELIMINARY

I

DO NOT SCALE THIS PRINT

CONFIDENTIAL AND TRADE SECRET INFORMATION OF RUSH ENTERPRISES, INC.

This document and the information in it is confidential, proprietary and trade secret information of Rush Enterprises, Inc. and its subsidiaries ("Rush"). It contains information intended only for the person to whom it is transmitted and may not be disclosed to any third party, in whole or in part, or used to manufacture anything shown or referred to herein, without Rush's express, written permission. This document must be returned to Rush on request.

Any form of reproduction, dissemination, copying, disclosure, modification, distribution and or publication of this document and the information contained herein is strictly prohibited.

This notice must appear on any complete or partial reproduction of this document or the information contained herein.

Copyright © 2016 Rush Enterprises, Inc. All rights reserved.

ALL DIMENSION TOLERANCES UNLESS NOTED
 ONE PLACE .X ±.06
 TWO PLACES .XX ±.03
 THREE PLACES .XXX ±.010
 FOUR PLACES .XXXX ±.0010
 ANGLES ±1.0°
 ALL MACHINED SURFACES TO BE 250 RMS UNLESS NOTED.

DRAWN KSA	4/16/2020	MOMENTUM FUEL TECHNOLOGIES 1051 Republic Drive, Suite 200 Roanoke, TX 76262	
CHECKED			
QA		TITLE BOC, 80 DGE, (2) LUXFER 22X86 TANKS, (1) LUXFER 16X81 TANK, 500KB AUTOCAR ACX, AUX FILL	
MFG		SIZE D	DWG NO 500-008000-00110014-500KB-AUTOCAR ACX
APPROVED		SCALE	REV
Part Mass N/A			SHEET 3 OF 8

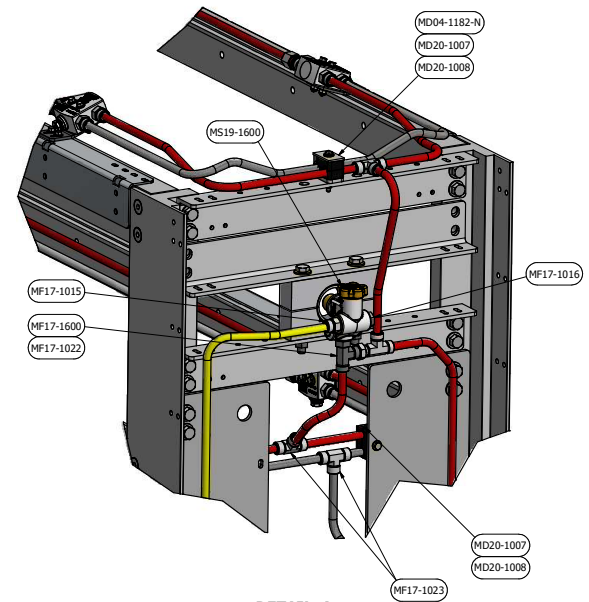
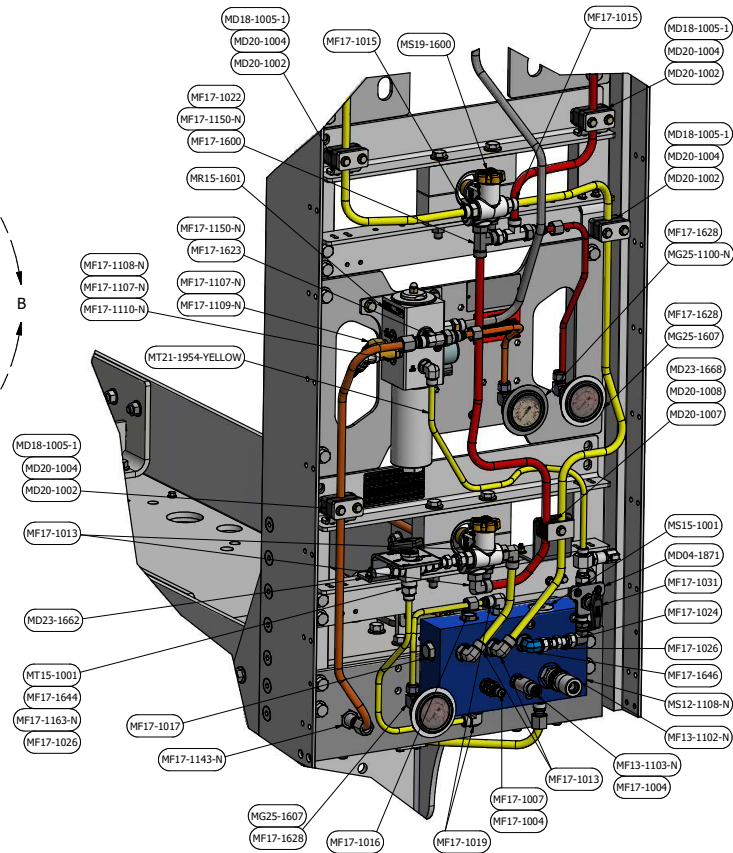
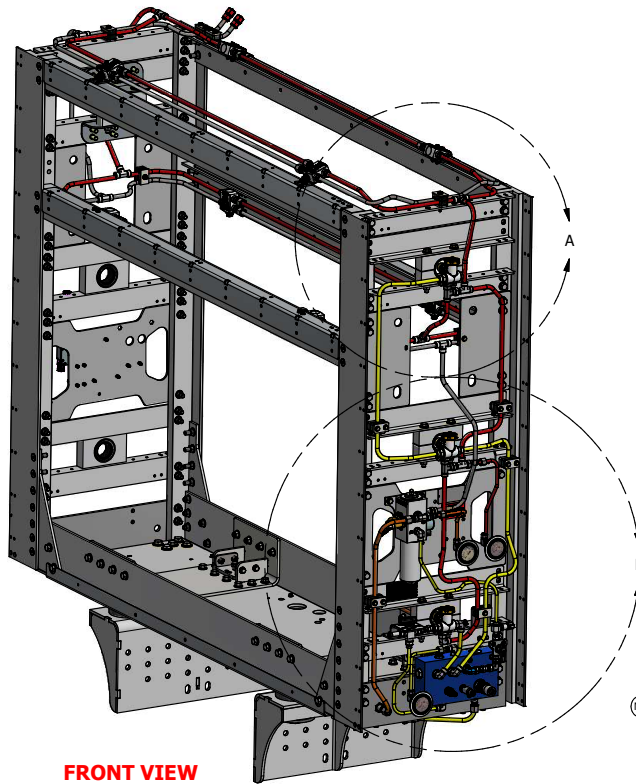

DRAWN	KSA	4/16/2020	MOMENTUM FUEL TECHNOLOGIES	
CHECKED			1051 Republic Drive, Suite 200 Roanoke, TX 76262	
QA			TITLE	
MPG			BOC, 80 DGE, (2) LUXFER 22X86 TANKS, (1) LUXFER 16X81 TANK, 500KB AUTOCAR ACX, AUX FILL	
APPROVED			SIZE	DWG NO
Part Mass	N/A		D	500-008000-00110014-500KB-AUTOCAR ACX
			SCALE	REV

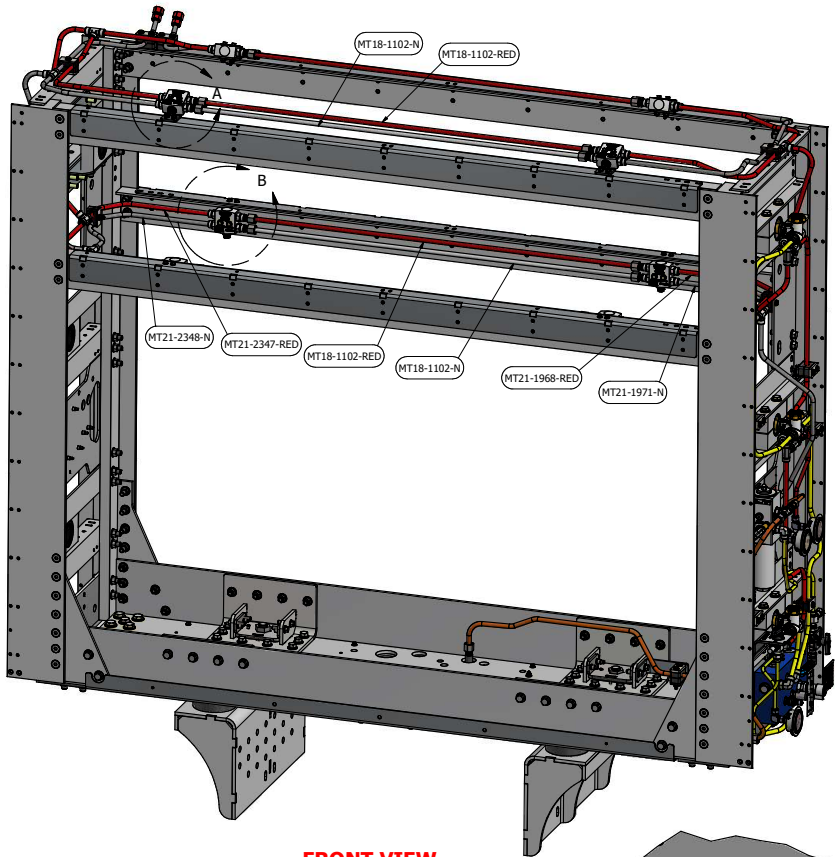

FRONT VIEW

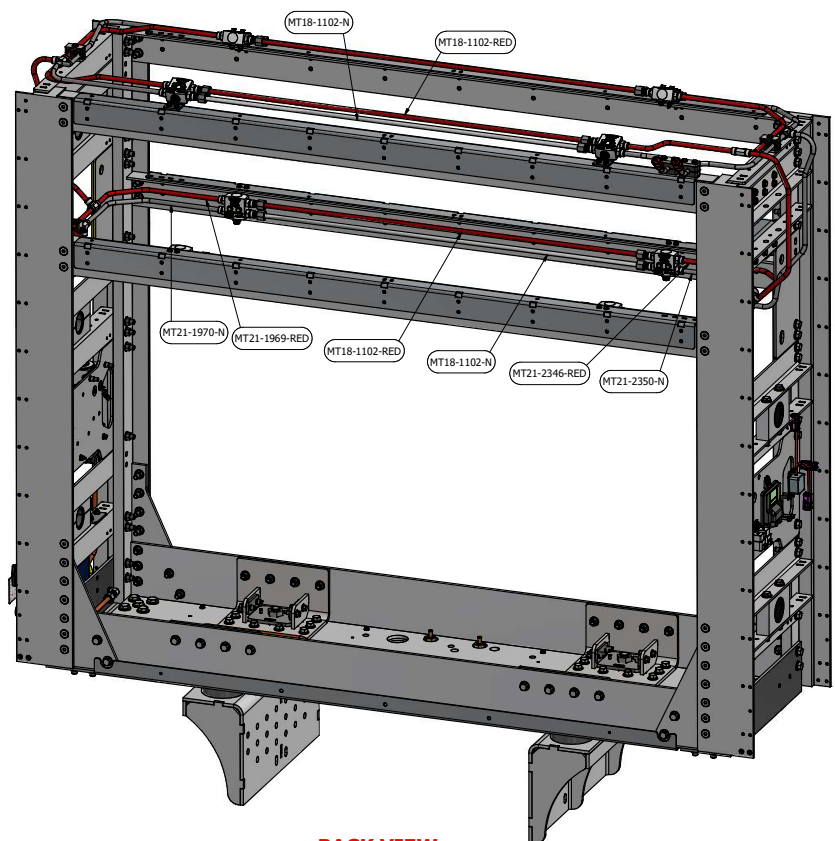

BACK VIEW

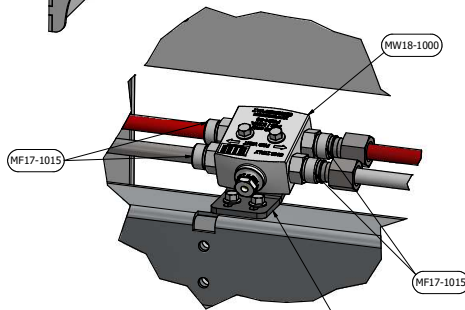

**DETAIL A
SCALE 1/2**

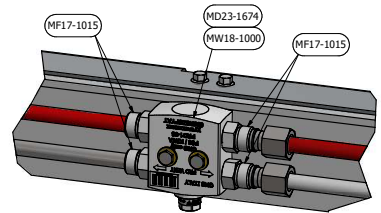

**DETAIL B
SCALE 1/2**

DRAWN	KSA	4/16/2020	MOMENTUM FUEL TECHNOLOGIES 1051 Republic Drive, Suite 200 Rowland, TX 76262	
CHECKED			TITLE BOC, 80 DGE, (2) LUXFER 22X86 TANKS, (1) LUXFER 16X81 TANK, 500KB AUTOCAR ACX, AUX FILL	
QA			SIZE	DWG NO
MFG			D	500-008000-00110014-500KB-AUTOCAR ACX
APPROVED			SCALE	REV
Part Mass	N/A			
				SHEET 5 OF 8

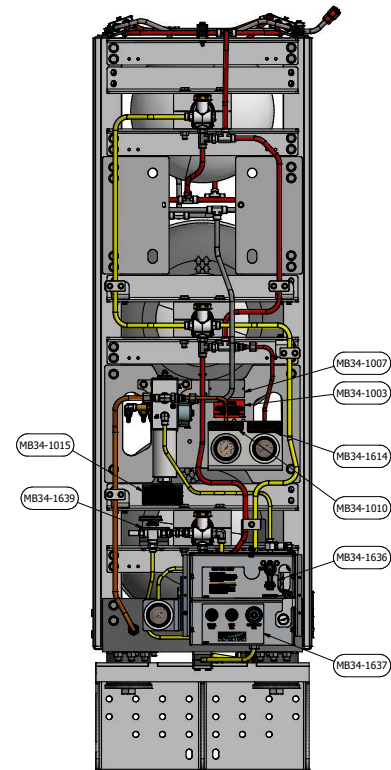
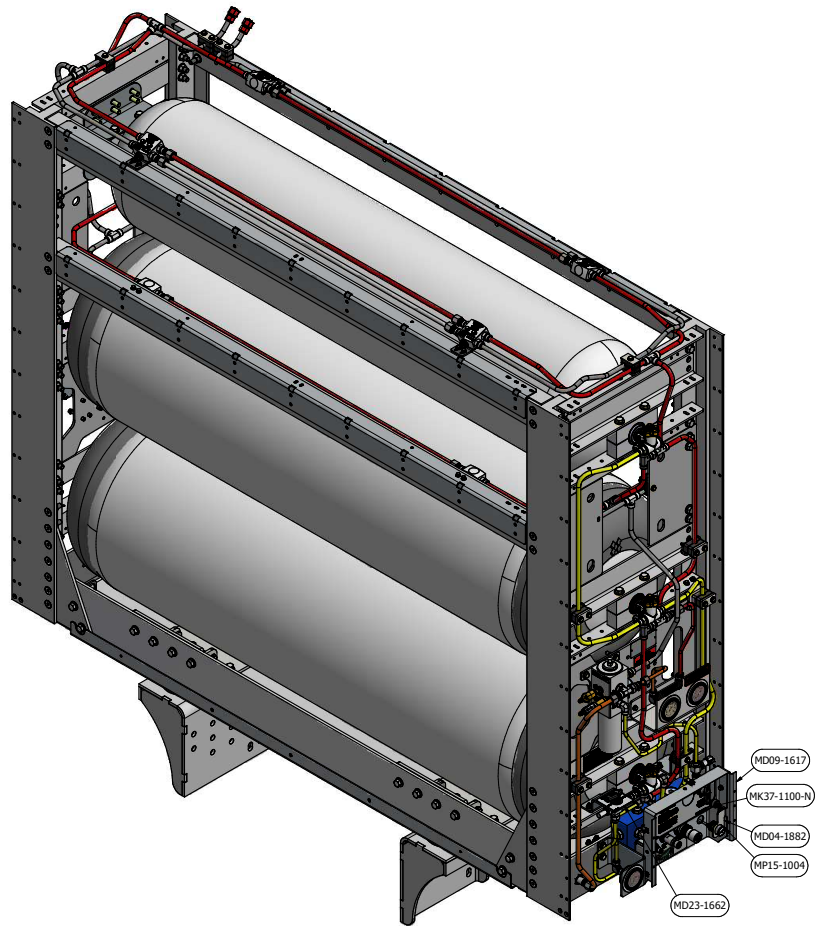

DRAWN KSA	4/16/2020	MOMENTUM FUEL TECHNOLOGIES 1051 Republic Drive, Suite 200 Rowland, TX 76262	
CHECKED		TITLE BOC, 80 DGE, (2) LUXFER 22X86 TANKS, (1) LUXFER 16X81 TANK, 500KB AUTOCAR ACX, AUX FILL	
QA		SIZE D	DWG NO 500-008000-0010014-500KB-AUTOCAR ACX
APPROVED		SCALE	REV
Part Mass N/A			
SHEET 6 OF 8			

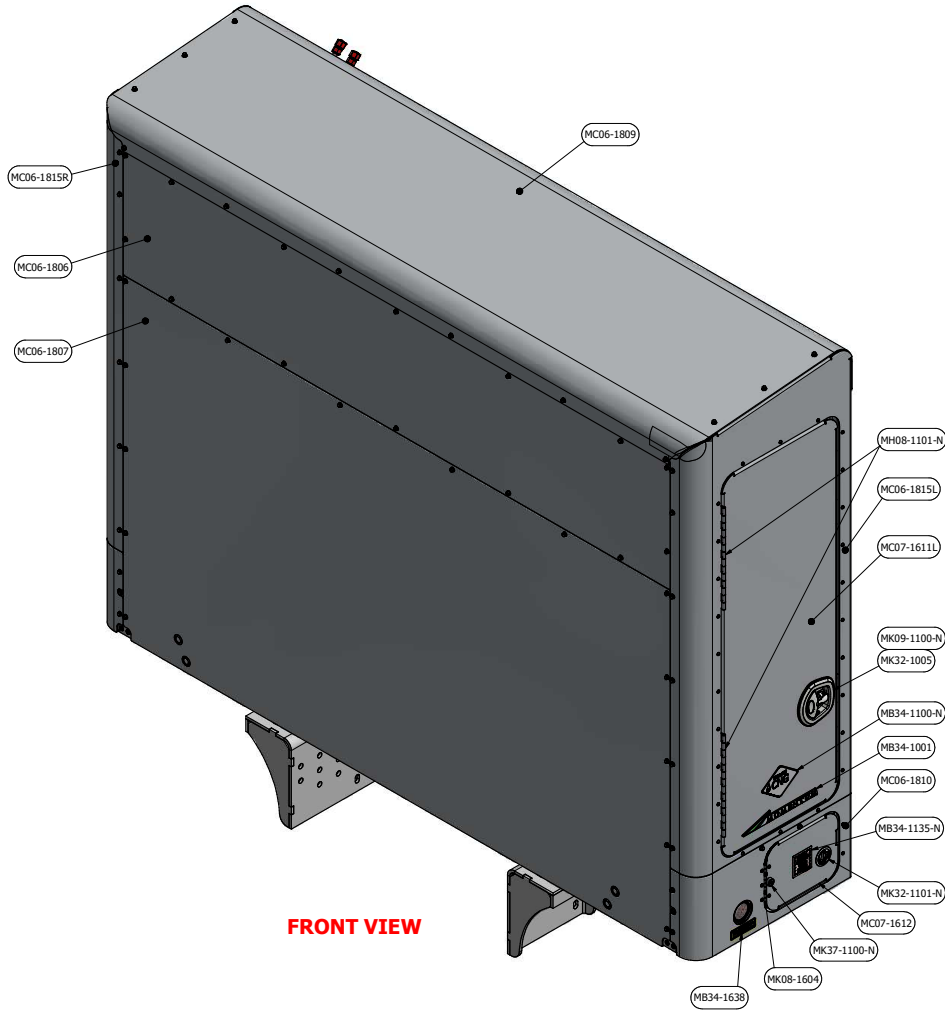

FRONT VIEW

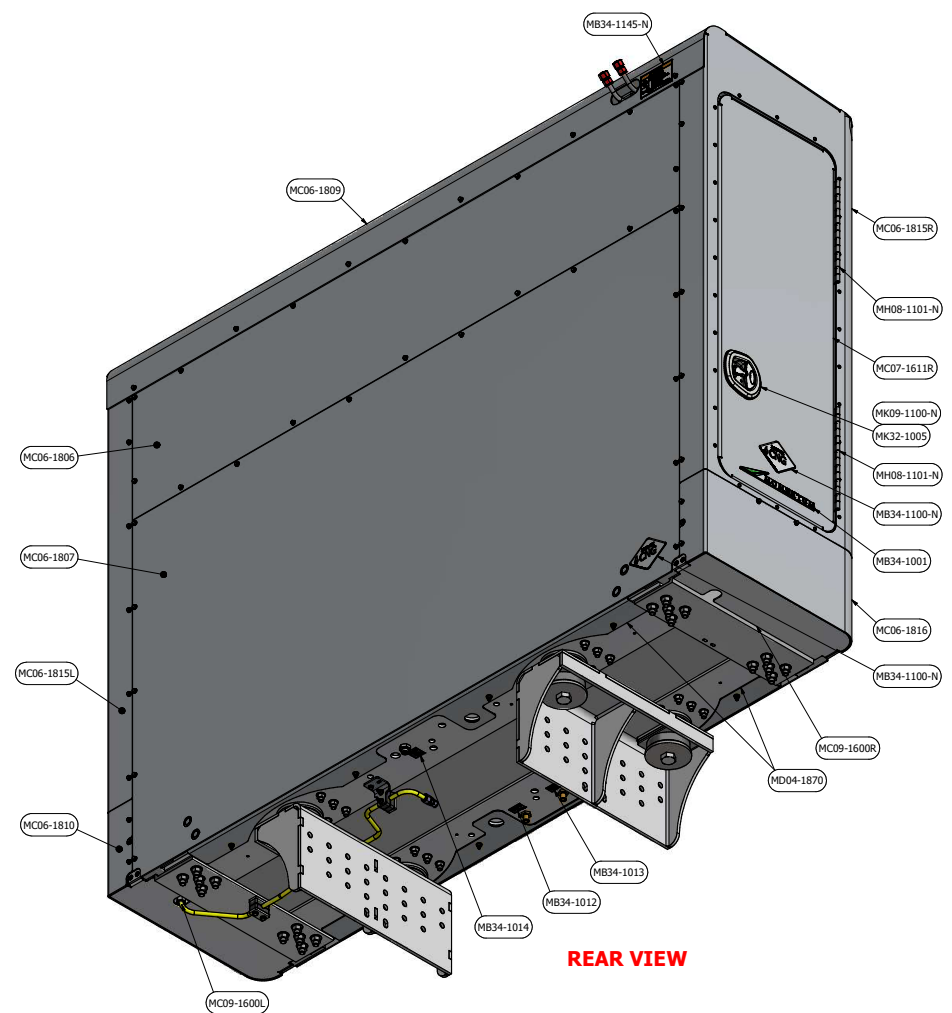

REAR VIEW

DRAWN KSA	4/16/2020	MOMENTUM FUEL TECHNOLOGIES 1051 Republic Drive, Suite 200 Rowland, TX 76262	
CHECKED		TITLE BOC, 80 DGE, (2) LUXFER 22X86 TANKS, (1) LUXFER 16X81 TANK, 500KB AUTOCAR ACX, AUX FILL	
QA		SIZE D	DWG NO 500-008000-00110014-500KB-AUTOCAR ACX
MFG		SCALE	REV
APPROVED		Part Mass N/A	
		SHEET 7 OF 8	

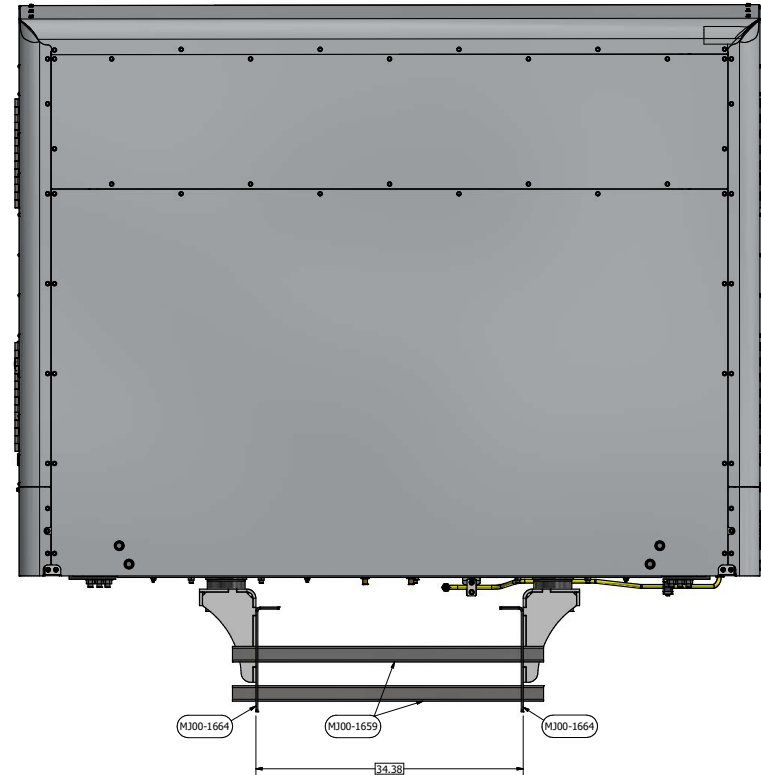
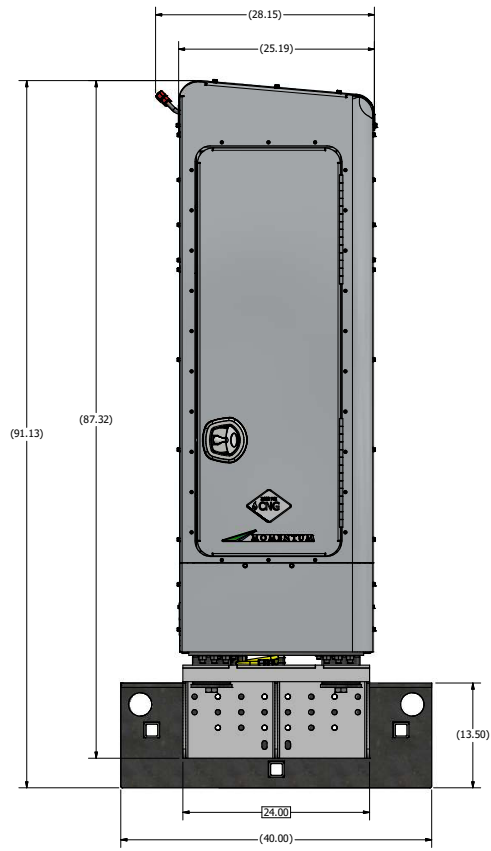

SHIPPING JIG

DRAWN KSA	4/16/2020	MOMENTUM FUEL TECHNOLOGIES 1051 Republic Drive, Suite 200 Roanoke, TX 76262	
CHECKED		M O M E N T U M FUELS	
QA		TITLE BOC, 80 DGE, (2) LUXFER 22X86 TANKS, (1) LUXFER 16X81 TANK, 500KB AUTOCAR ACX, AUX FILL	
APPROVED		SIZE D	DWG NO 500-008000-00110014-500KB-AUTOCAR ACX
Part Mass N/A		SCALE	REV
			SHEET 8 OF 8