

PARTS LIST			
ITEM	QTY	PART NUMBER	DESCRIPTION
1	2	MB34-1003	DECAL - DANGER
2	1	MB34-1007	Label - Serial Number Tag
3	1	MB34-1015	Decal - Fuel Container Life
4	1	MB34-1100-N	Decal - 3600 PSI CNG
5	1	MB34-1135-N	DECAL - MANUAL SHUT OFF VALVE INSIDE
6	1	MB34-1171-N	DECAL - FMM - STAND ALONE
7	1	MB34-1172-N	DECAL - FMM - STAND ALONE
8	1	MB34-1173-N	DECAL - FMM - STAND ALONE
9	1	MB34-1176-N	DECAL - COOLANT IN/COOLANT OUT
10	1	MB34-1180-N	DECAL - FUEL CONTAINER LIFE
11	2	MC06-1185-N	SPACER - HINGE, VERTICAL FMM
12	1	MC06-1188-N	SPACER - LATCH CATCH, VERTICAL FMM
13	1	MC06-1669	Cover-Electrical Box, Vertical FMM
14	1	MC06-1714	COVER - TOP, SHORT VERTICAL FMM
15	1	MC06-1715	COVER - BOTTOM, SHORT VERTICAL FMM
16	1	MC06-1716	COVER - SIDE, SHORT VERTICAL FMM
17	1	MC07-1145-N	COVER - FILTER DOOR, VERTICAL FMM
18	1	MC07-1608	COVER - FRONT DOOR, VERTICAL FMM
19	1	MD04-1199-N	BRACKET - PROX TARGET, VERTICAL FMM
20	1	MD04-1693	COVER - PANE, FRONT, VERTICAL FMM
21	1	MD04-1694	COVER - PANEL, BACK, VERTICAL FMM
22	1	MD04-1695	COVER - PANEL, BACK, VERTICAL FMM
23	1	MD04-1700	BRACKET - MOUNTING, SHORT VERTICAL FMM
24	1	MD04-1705	BRACKET - MOUNTING, VERTICAL FMM
25	2	MD04-1707	BRACKET - MOUNTING, VERTICAL FMM
26	1	MD04-1721	WELDMENT - MOUNTING BASE, SHORT VERTICAL FMM
27	1	MF13-1000	RECEPTACLE - HEAVY DUTY FILL
28	1	MF13-1001	RECEPTACLE - NGV1 FILL
29	1	MF14-1004	PLUG - #6 ORING BOSS
30	1	MF14-1101-N	#10 ORING BOSS HOLLOW HEX PLUG
31	1	MF17-1004	FITTING - UNION - STRAIGHT - #6 ORING X # 6 ORING (9/16"-18)
32	1	MF17-1007	DEFUEL NIPPLE - 316SS -6 SAE CNG
33	1	MF17-1013	ELBOW - 90° 1/2" STANDARD O-RING X 1/2" ORFS (O-RING FACE SEAL)
34	1	MF17-1015	ADAPTER - STRAIGHT - #8 ORING BOSS X #8 ORFS
35	1	MF17-1018	ADAPTER - BULKHEAD - STRAIGHT - #6 ORFS X #6 ORING BOSS
36	4	MF17-1019	ADAPTER - 90° ELBOW - #6 ORING BOSS X #6 ORFS
37	4	MF17-1024	FITTING - 90° ELBOW-6 ORFS MALE X -6 ORFS FEMALE SWIVEL
38	1	MF17-1025	FITTING - TEE - SWIVEL RUN -6 FEMALE SWIVEL X-6X-6 ORFS
39	1	MF17-1031	VALVE - 2 WAY, -6 ORFS
40	2	MF17-1141-N	ADAPTER - STRAIGHT #6 (3/8") ORFS X #6 (3/8") TUBE
41	3	MF17-1149-N	ADAPTER - #6 ORFS (MALE) X #6 ORING BOSS (MALE)
42	1	MF17-1163-N	VALVE - 3 WAY, #6 ORFS X #6 ORFS X 1/4" NPT (RATED FOR 6,000 PSI MIN)
43	2	MF17-1172-N	ADAPTER, STRAIGHT, BRASS 3/8" NPT X 5/8" HOSE BARB
44	1	MF17-1185-N	ADAPTER - TEE, RUN #6 STANDARD ORING BOSS (MALE) X #8 ORFS (MALE) X #8 ORFS (MALE)
45	1	MF17-1186-N	CONNECTOR-MALE, 9/16-18 #6 MALE ORB X 3/8" TUBE
46	1	MF17-1610	PURGE VALVE WITH SS BALL
47	1	MF17-1611	ELBOW-MALE POSITIONABLE, 3/8" TUBE X #6 MALE ORB
48	1	MF17-1622	ADAPTER - ELBOW, #10 ORB X #10 MALE JIC
49	1	MG25-1100-N	LP Gauge, Crimped, w/ Logo
50	1	MG25-1101-N	HP Gauge, Crimped, w/ Logo
51	1	MH24-1600	5/8" ID X 1-1/8" OD RUBBER GROMMET

PARTS LIST			
ITEM	QTY	PART NUMBER	DESCRIPTION
52	3	MH24-1002	ECM Grommet-3/8" bore diameter
53	1	MH24-1601	3/8" ID X 7/8" OD RUBBER GROMMET
54	18	MH27-1001-004-20-100-YZ-008-HH	BOLT - HEX HEAD, 1/4"-20 X 1" LONG, GRADE 8, YELLOW ZINC
55	4	MH27-1001-004-20-275-YZ-008-HH	BOLT - HEX HEAD, 1/4"-20 X 2-3/4" LONG, GRADE 8, YELLOW ZINC
56	2	MH27-1001-004-20-325-ZN-008-HH	BOLT - HEX HEAD, 1/4"-20 X 3-1/4" LONG, GRADE 8, ZINC
57	8	MH27-1001-004-20-375-YZ-008-HH	BOLT - HEX HEAD, 1/4"-20 X 3-3/4" LONG, GRADE 8, YELLOW ZINC
58	8	MH27-1001-006-16-100-YZ-008-HH	BOLT - HEX HEAD, 3/8"-16 X 1" LONG, GRADE 8, YELLOW ZINC
59	7	MH27-1001-006-16-125-YZ-008-HH	BOLT - HEX HEAD, 3/8"-16 X 1-1/4" LONG, GRADE 8, YELLOW ZINC
60	4	MH27-1001-006-16-200-YZ-008-HH	BOLT - HEX HEAD, 3/8"-16 X 2" LONG, GRADE 8, YELLOW ZINC
61	10	MH27-1001-008-13-200-YZ-008-HH	1/2"-13 X 2" HEX HEAD BOLT
62	8	MH27-1001-M06-32-075-SS-188-BH	SCREW- BUTTON HEAD, #6-32 X 3/4" LONG, 18-8 STAINLESS STEEL
63	2	MH27-1001-M10-32-100-ZN-008-PH	SCREW - MACHINE, PAN HEAD #10-32 X 1" LONG, ZINC
64	2	MH27-1002-M08-125-020-YZ-109-HH	M8-1.25 x 20 GR(10.9) Yellow Zinc Hex Cap Screw
65	19	MH27-1003-004-20-YZ-008-NL	NYLON LOCKNU GR.8 1/4-20
66	8	MH27-1003-006-16-YZ-008-NL	NUT -NYLON LOCKING, 3/8"-16, YELLOW ZINC GRADE 8
67	10	MH27-1003-008-13-YZ-008-NL	NUT - NYLON LOCKING, 1/2"-13, YELLOW ZINC GRADE 8
68	8	MH27-1003-M06-32-SS-008-NL	NUT - NYLON LOCKING, #6-32, STAINLESS STEEL GRADE 8
69	2	MH27-1003-M10-24-ZN-002-NL	NUT - NYLON LOCKING, #10-24, ZINC GRADE 2
70	51	MH27-1004-004-FL-YZ-008	SAE Washer-1/4"-.625" od yellow zinc washer
71	45	MH27-1004-006-FL-YZ-008	SAE Washer-3/8"-.8125" od yellow zinc washer
72	20	MH27-1004-008-FL-YZ-008	SAE Washer-1/2"-1.0625" od yellow zinc washer
73	4	MH27-1004-M10-FL-ZN	WASHER - FLAT , #10, ZINC
74	13	MH27-1009	NUT - HALF HEX RIVET - 1/4"-20 (GRIP RANGE 0.165-0.260)
75	15	MH27-1010	NUT - HALF HEX RIVET, 3/8"-16, GRADE 5, (GRIP RANGE 0.150" - 0.312")
76	3	MK08-1000	ACCESSORIES - HINGE, BUTT
77	1	MK32-1101-N	LATCH - RECESSED PULL HANDLE, SPRING LOADED
78	1	MK32-1103-N	LATCH - PANEL, MEDIUM, KNURLED HEAD, STAINLESS STEEL
79	1	MP10-1000	ECU
80	1	MP10-1001	FLIM - (FUEL LEVEL INDICATOR MODULE)
81	2	MP15-1000	RELAY, MINI (SPDT) CHANGE-OVER W/BRKT AND RESISTOR
82	1	MP15-1003	PRESSURE TRANSDUCER, 1-5 volt output, 0-6000 psi
83	1	MP15-1004	SENSOR - PROXIMITY W/ CONNECTOR
84	1	MP92-1027	HARNESS- ELECTRONICS HEIL VERTICAL FMM
85	1	MR15-1102-N	REGULATOR-PARKER FM80 VERIFLO, CNG RH CONFIGURATION
86	1	MS12-1104-N	MANIFOLD-FRONT FILL, VERTICAL FMM
87	1	MS12-1106-N	MANIFOLD-HIGH PRESSURE, VERTICAL FMM
88	1	MS12-1107-N	MANIFOLD - REAR FUEL, DUAL REMOTE FILL
89	1	MS15-1001	VALVE_CARTRIDGE_CHECK
90	1	MT15-1001	MUFFLER - STEEL 1/4" NPT - 105 SCFM 1-3/4 HEIGHT
91	1	MT21-1497-YELLOW	TUBE-3/8", SHUTOFF VALVE OUTLET TO MANIFOLD, VERTICAL FMM
92	1	MT21-1498-YELLOW	TUBE-3/8", DEFUEL VALVE COMMON TO DEFUEL COUPLING, VERTICAL FMM
93	1	MT21-1499-YELLOW	TUBE-3/8", TEE TO SHUTOFF VALVE INLET, VERTICAL FMM
94	1	MT21-1504-YELLOW	TUBE-3/8", MANIFOLD TO DEFUEL VALVE INLET VERTICAL FMM
95	1	MT21-1817-N	TUBE- 3/8", MANIFOLD TO LOW PRESSURE GAUGE, SHORT VERT.FMM
96	1	MT21-1818-YELLOW	TUBE- 3/8", MANIFOLD TO MANIFOLD, SHORT VERT.FMM
97	1	MT21-1819-YELLOW	TUBE- 3/8", TEE TO HIGH PRESSURE GAUGE, SHORT VERT.FMM
98	1	MT21-1820-YELLOW	TUBE- 3/8", MANIFOLD TO TEE, SHORT VERT.FMM
99	1	MT21-1821-N	TUBE- 1/2", REGULATOR TO MANIFOLD, SHORT VERT.FMM
100	1	MT21-1822-YELLOW	TUBE- 3/8", MANIFOLD TO REGULATOR, SHORT VERT.FMM
101	1	SS-810-2-8ST	PURGE VALVE W/ SS BALL

ALL DIMENSION TOLERANCES UNLESS NOTED
ONE PLACE .X ±.06
TWO PLACES .XX ±.03
THREE PLACES .XXX ±.010
FOUR PLACES .XXXX ±.0010
ANGLES ±1.0°
ALL MACHINED SURFACES TO BE 250 RMS UNLESS NOTED.

- NOTES:
- FOR INFORMATION NOT CONTAINED IN THIS PRINT REFERENCE THE MATH DATA FOR THIS PART (MN39-1610)
 - ALL DIMENSIONS ARE IN INCHES
 - PART SHALL BE FREE OF BURRS, FLASH AND SHARP EDGES
 - PART NUMBER, REV LEVEL, AND SUPPLIER CODE REQUIRED ON ALL PARTS. REFER TO DRAWING FOR SPECIFIC LOCATION, WHERE APPLICABLE. ETCH, STAMP, OR OTHERWISE PERMANENTLY ATTACH REQUIRED INFORMATION ON LARGER PARTS. PERMANENT MARKINGS SHALL BE PLACED IN SUCH A WAY THAT THEY ARE VISIBLE AFTER PART IS COATED OR PAINTED. SMALLER PARTS SHOULD HAVE THE INFORMATION ATTACHED BY THE BEST METHOD POSSIBLE. ALTERNATE MEANS OF ATTACHING INFORMATION MUST BE APPROVED.

PRELIMINARY

I

DO NOT SCALE THIS PRINT

CONFIDENTIAL AND TRADE SECRET INFORMATION OF NATURAL GAS FUEL SYSTEMS, INC. dba MOMENTUM FUEL TECHNOLOGIES
This document and the information in it is confidential, proprietary and trade secret information of Natural Gas Fuel Systems, Inc. dba Momentum Fuel Technologies on behalf of itself and its subsidiaries and affiliates ("Momentum"). It contains information intended only for the person to whom it is transmitted and may not be disclosed to any third party, in whole or in part, or used to manufacture anything shown or referred to herein, without Momentum's express, written permission. This document must be returned to Momentum on request.

Any form of reproduction, dissemination, copying, disclosure, modification, distribution, and or publication of this document and the information contained herein is strictly prohibited.

This notice must appear on any complete or partial reproduction of this document or the information contained herein.

Copyright © 2016 Natural Gas Fuel Systems, Inc. dba Momentum Fuel Technologies. All rights reserved.

DRAWN	KSA	11/30/2017	MOMENTUM FUEL TECHNOLOGIES 1051 Republic Drive, Suite 200 Roanoke, TX 76262	
CHECKED				
QA			ASSY-FMM, VERTICAL, SHORT	
MFG				
APPROVED			SIZE	DWG NO
Part Mass			D	MN39-1610
			SCALE	REV

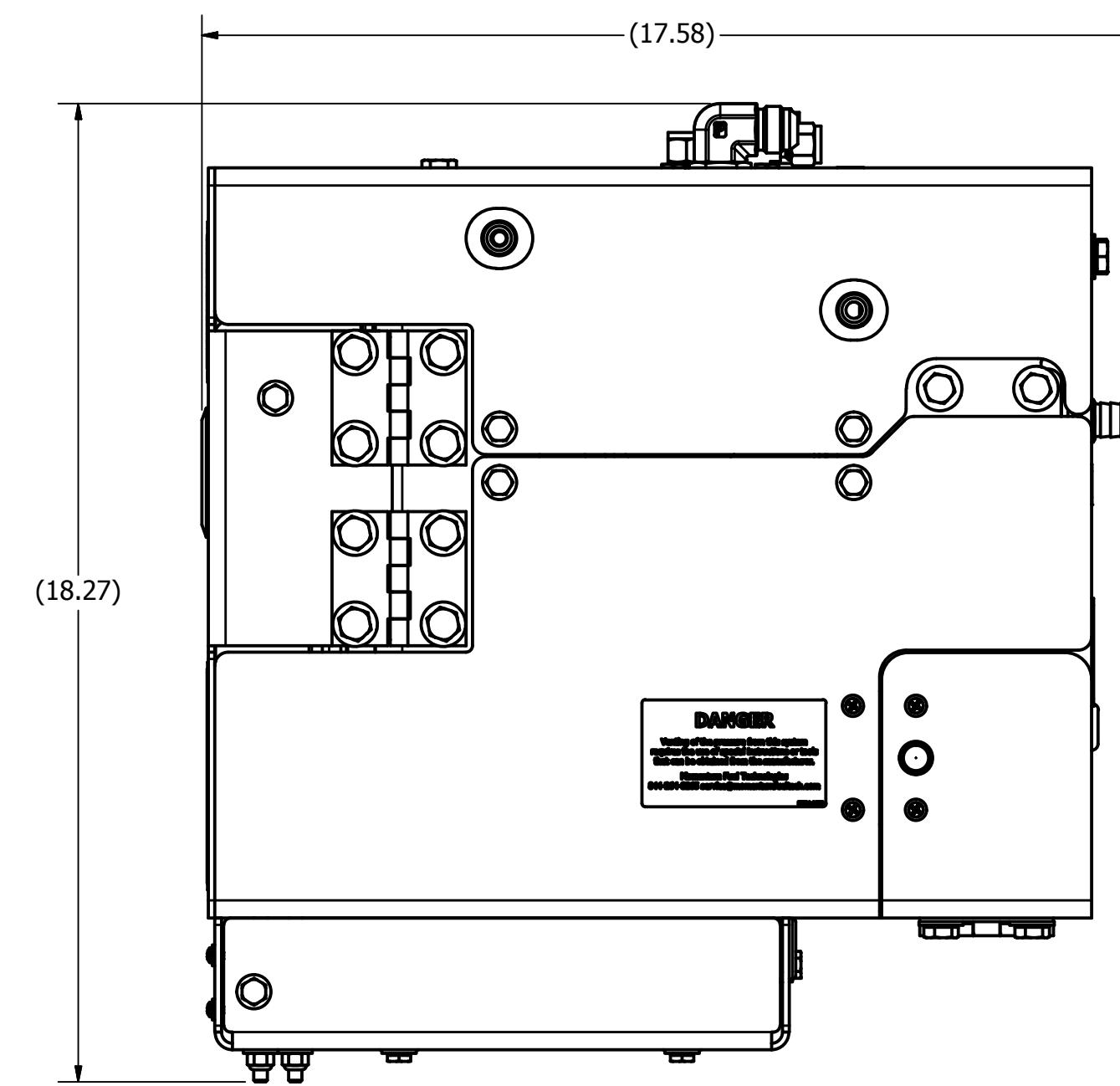
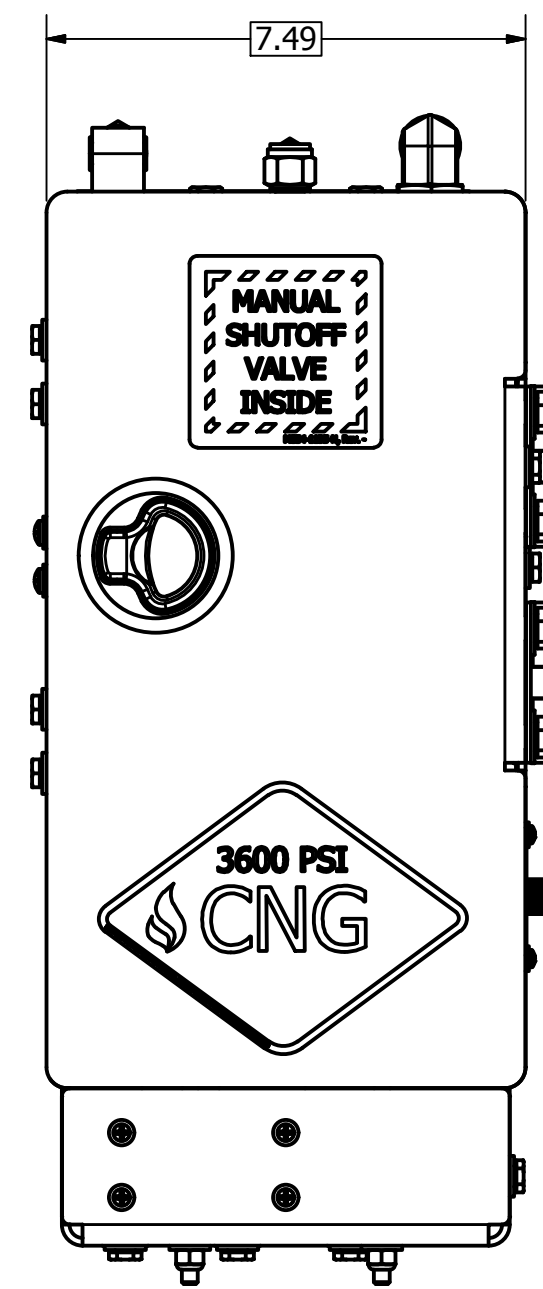
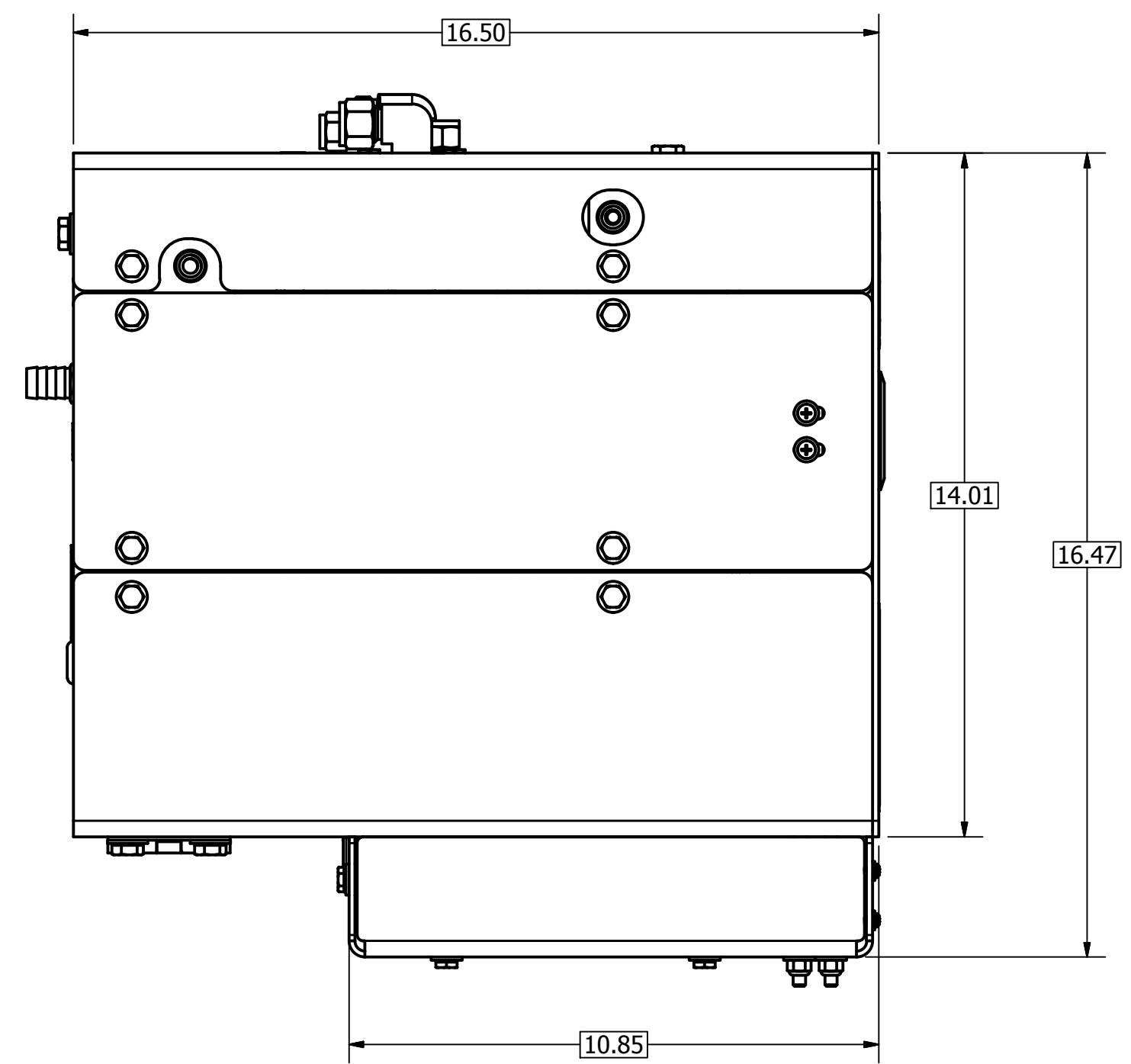

PRELIMINARY

CONFIDENTIAL AND TRADE SECRET INFORMATION OF NATURAL GAS FUEL SYSTEMS, INC. dba MOMENTUM FUEL TECHNOLOGIES

This document and the information in it is confidential, proprietary and trade secret information of Natural Gas Fuel Systems, Inc. dba Momentum Fuel Technologies on behalf of itself and its subsidiaries and affiliates ("Momentum"). It contains information intended only for the person to whom it is transmitted and may not be disclosed to any third party, in whole or in part, or used to manufacture anything shown or referred to herein, without Momentum's express, written permission. This document must be returned to Momentum on request.

Any form of reproduction, dissemination, copying, disclosure, modification, distribution, and or publication of this document and the information contained herein is strictly prohibited.

This notice must appear on any complete or partial reproduction of this document or the information contained herein.

Copyright © 2016 Natural Gas Fuel Systems, Inc. dba Momentum Fuel Technologies. All rights reserved.

ALL DIMENSION TOLERANCES UNLESS NOTED

ONE PLACE	.X	±.06
TWO PLACES	.XX	±.03
THREE PLACES	.XXX	±.010
FOUR PLACES	.XXXX	±.0010
ANGLES		±1.0°
ALL MACHINED SURFACES TO BE 250 RMS UNLESS NOTED.		

DRAWN KSA	11/30/2017	MOMENTUM FUEL TECHNOLOGIES 1051 Republic Drive, Suite 200 Roanoke, TX 76262		
CHECKED				
QA		OVERALL DIMENSIONS		
MFG				
APPROVED		SIZE D	DWG NO MN39-1610	REV
Part Mass N/A		SCALE		SHEET 2 OF 4

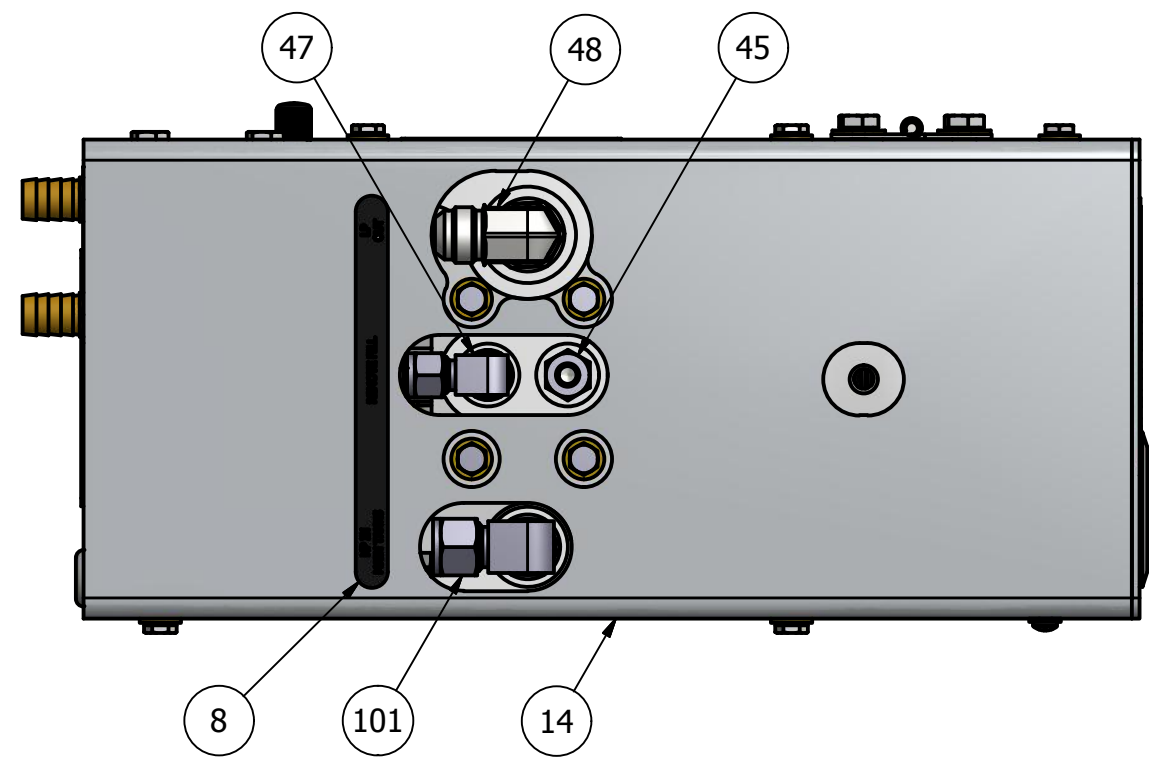

TOP VIEW

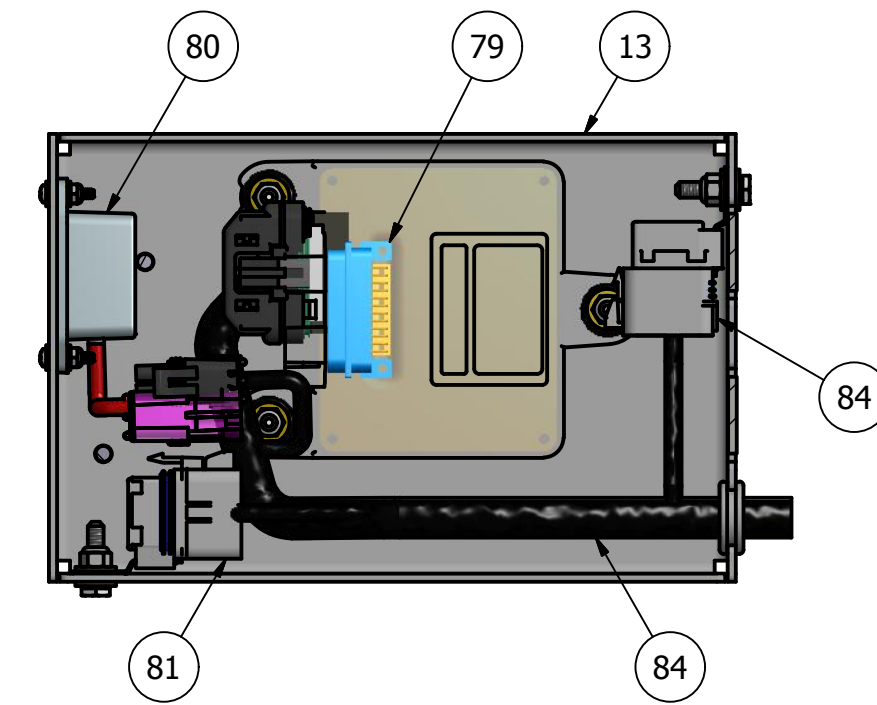

SECTION A-A
SCALE 1 / 3

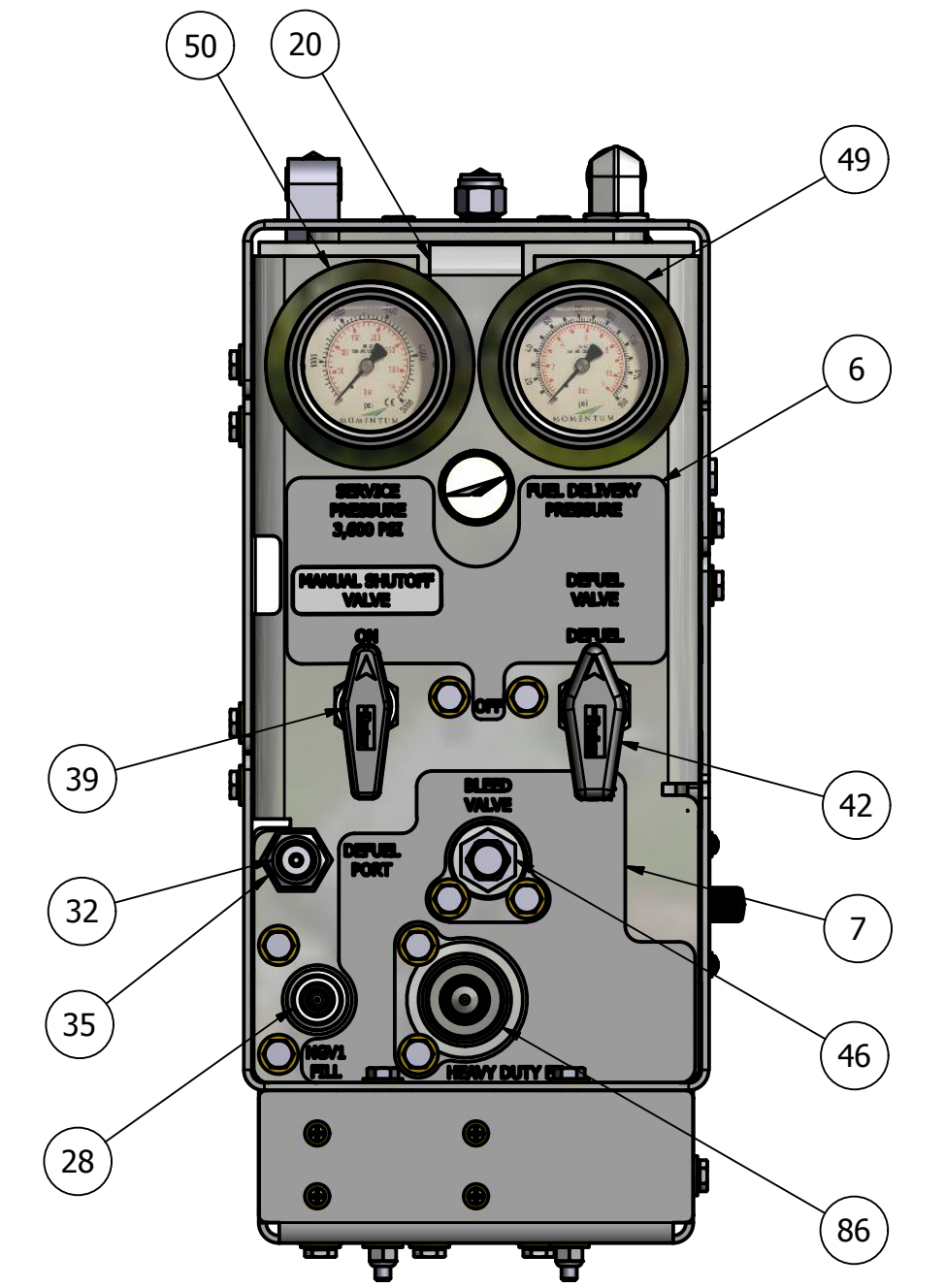

FRONT VIEW

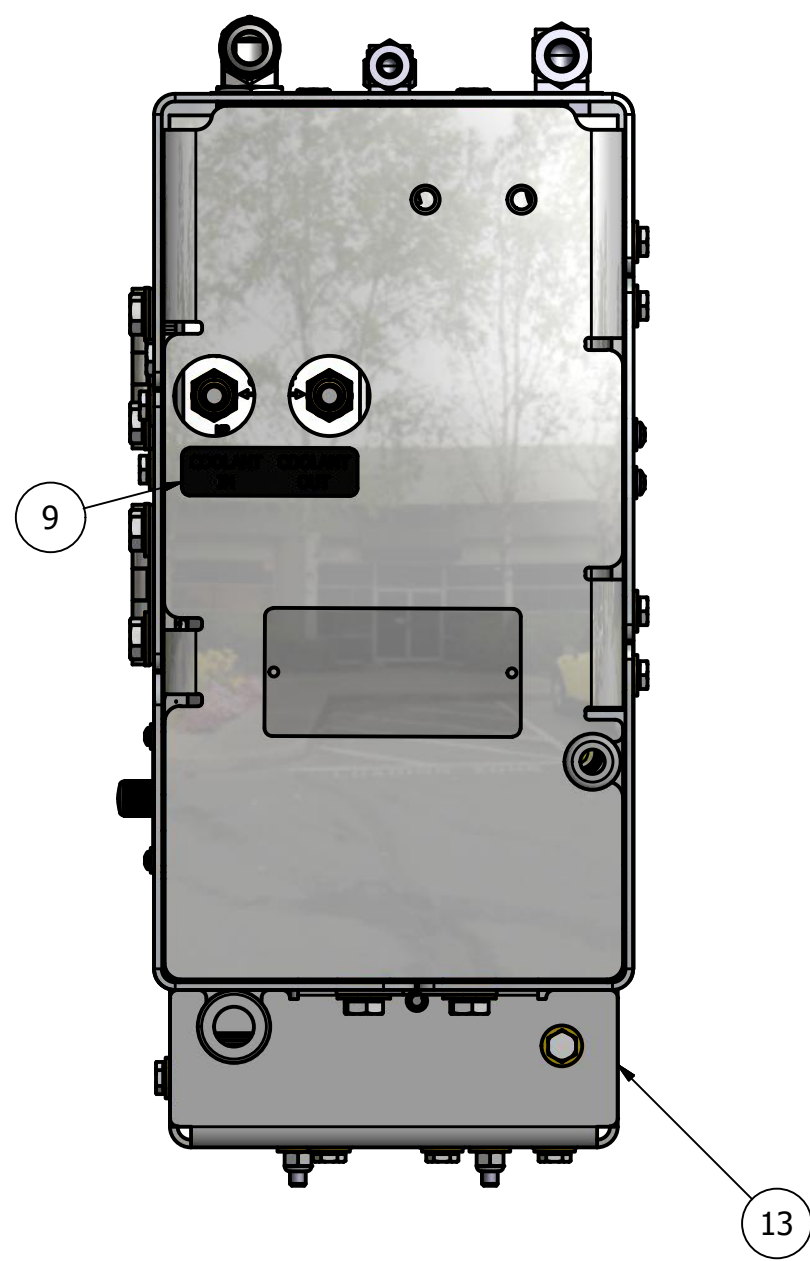

BACK VIEW

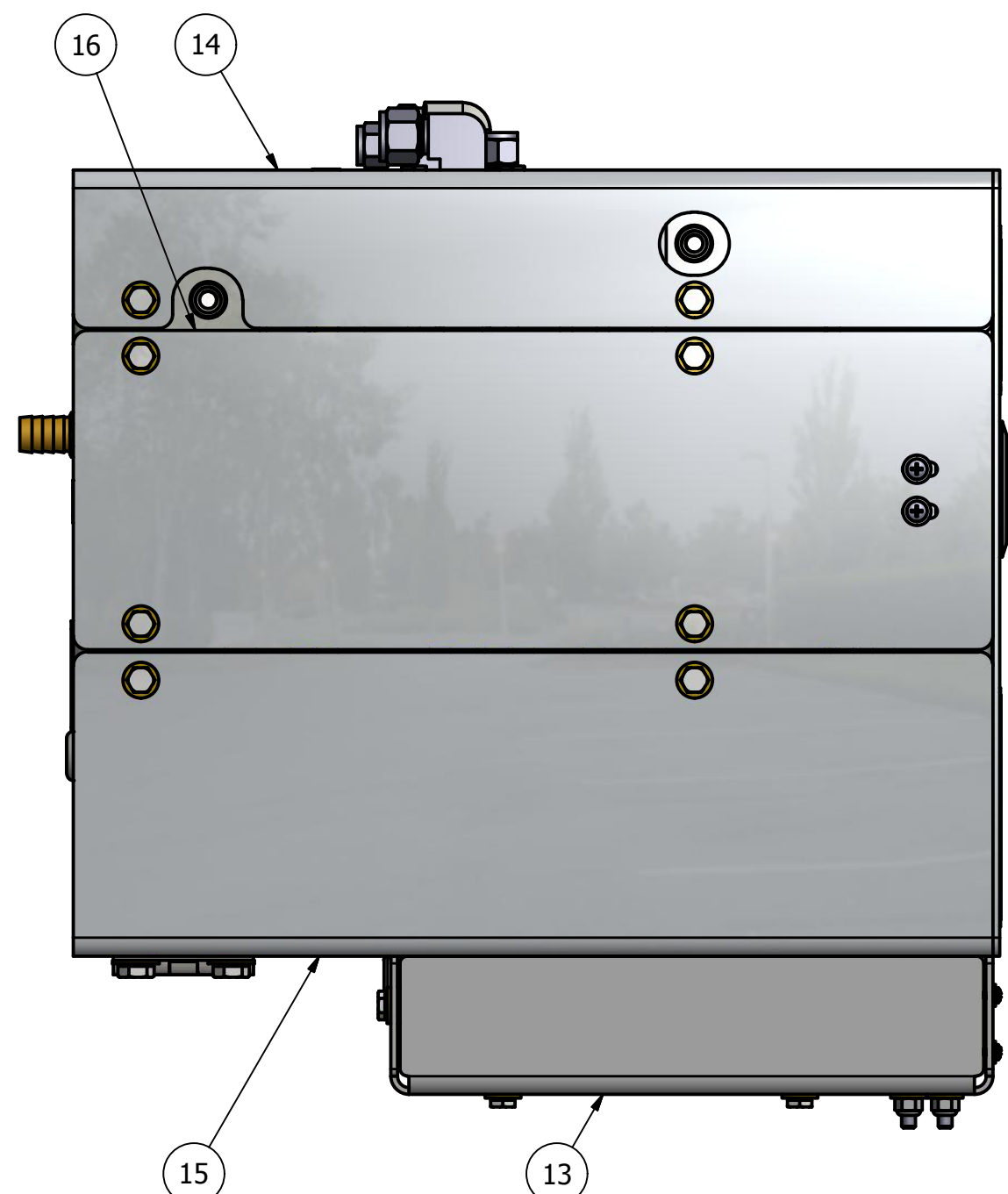

SIDE VIEW

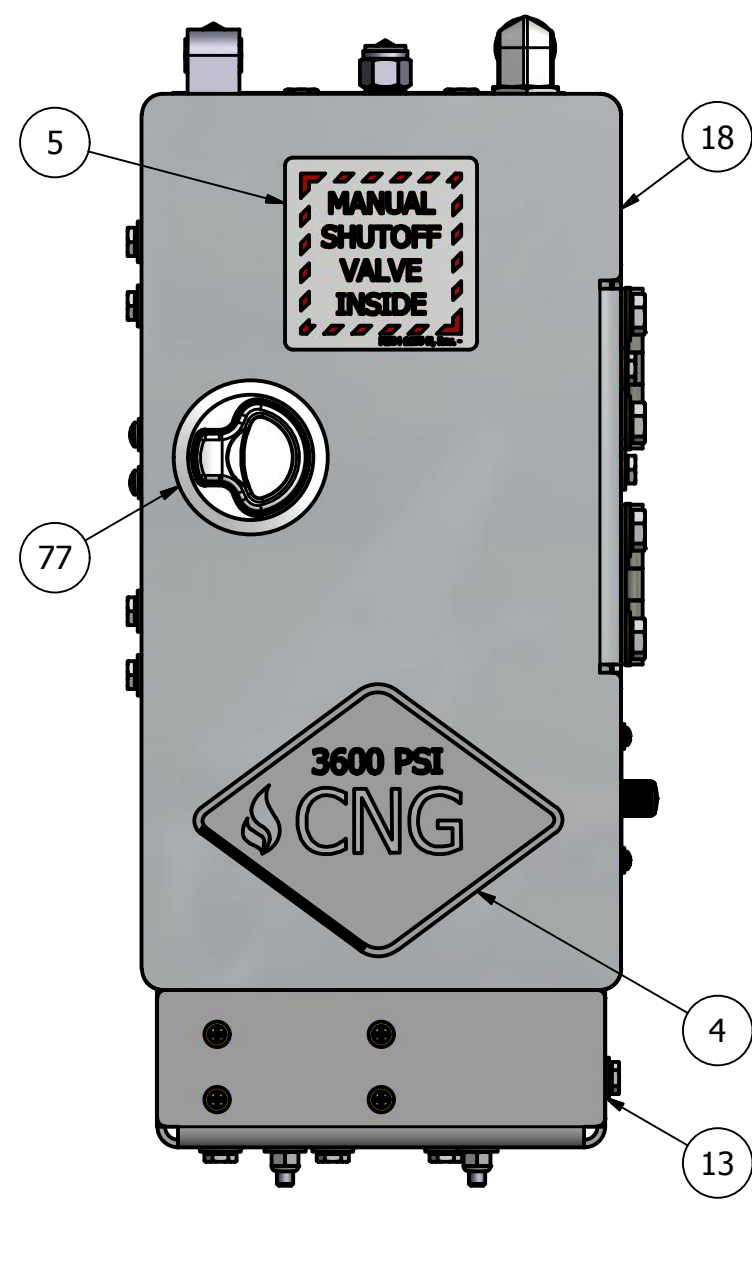

FRONT VIEW

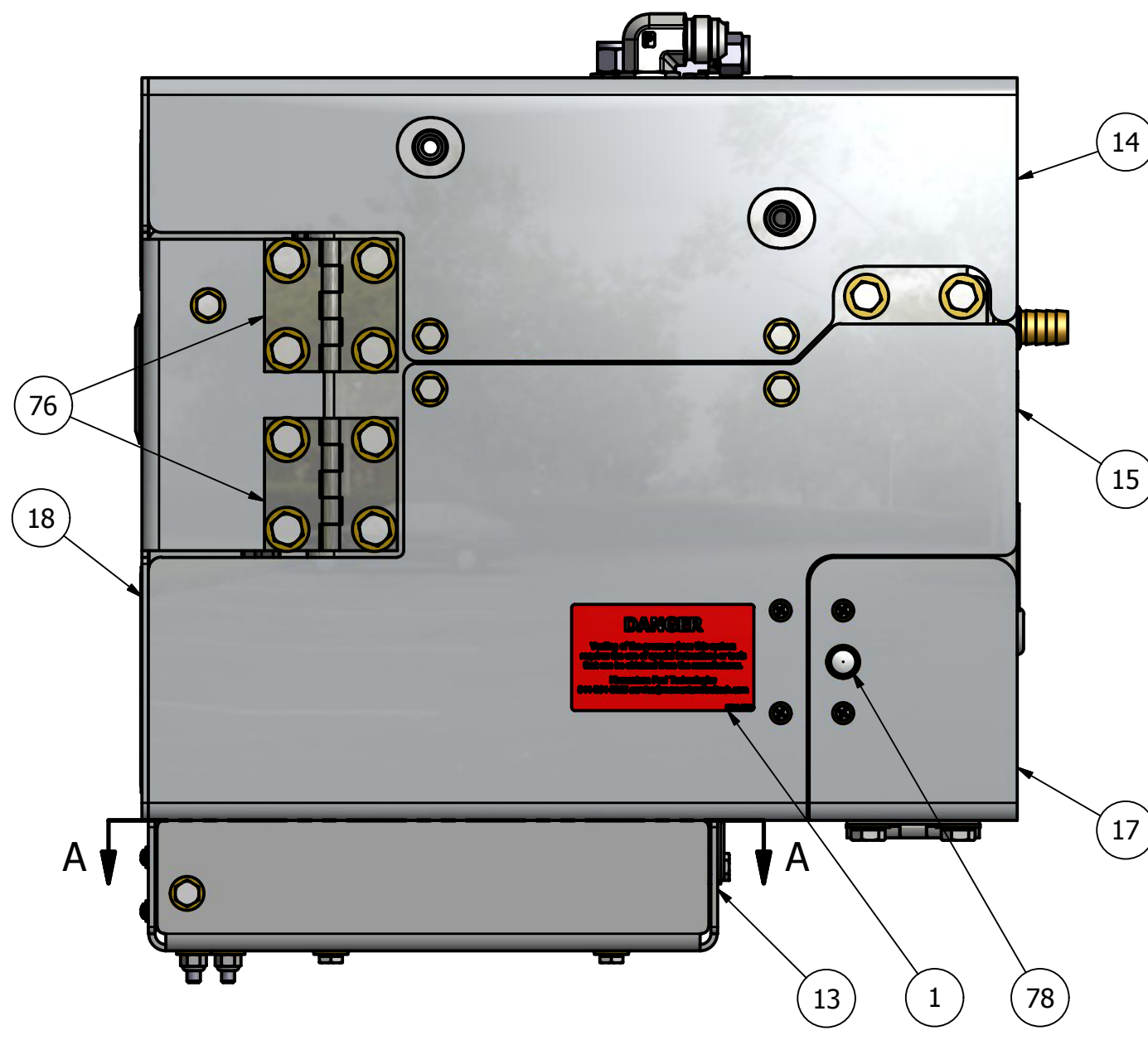

SIDE VIEW

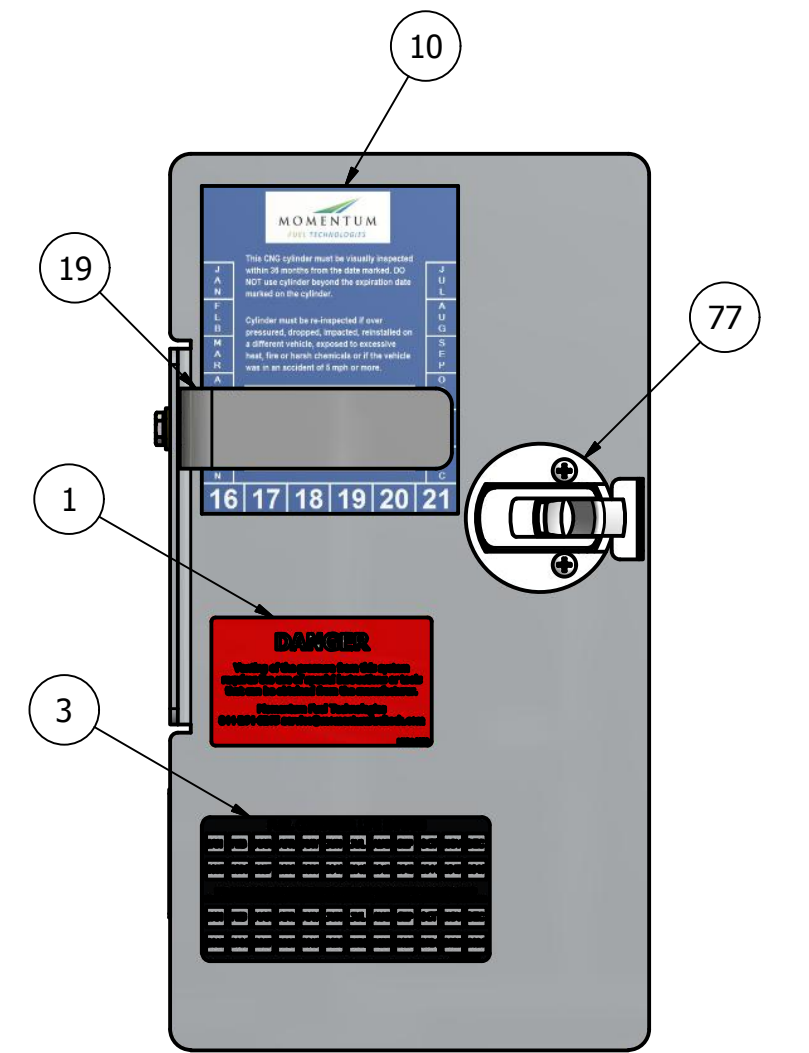

INSIDE DOOR VIEW

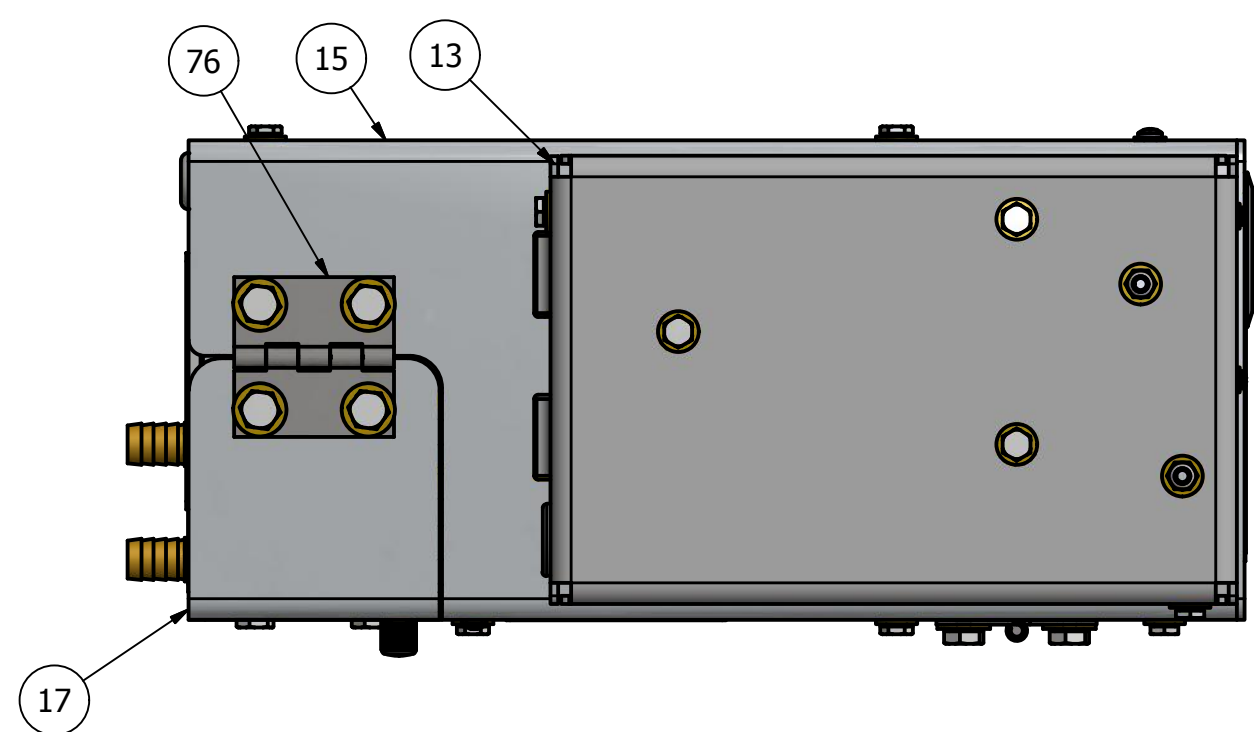

BOTTOM VIEW

PRELIMINARY

DRAWN	KSA	11/30/2017	MOMENTUM FUEL TECHNOLOGIES 1051 Republic Drive, Suite 200 Roanoke, TX 76262	
CHECKED			TITLE OUTER PARTS MARKED	
QA			SIZE	DWG NO
MFG			D	MN39-1610
APPROVED			SCALE	REV
Part Mass	N/A			
				SHEET 3 OF 4

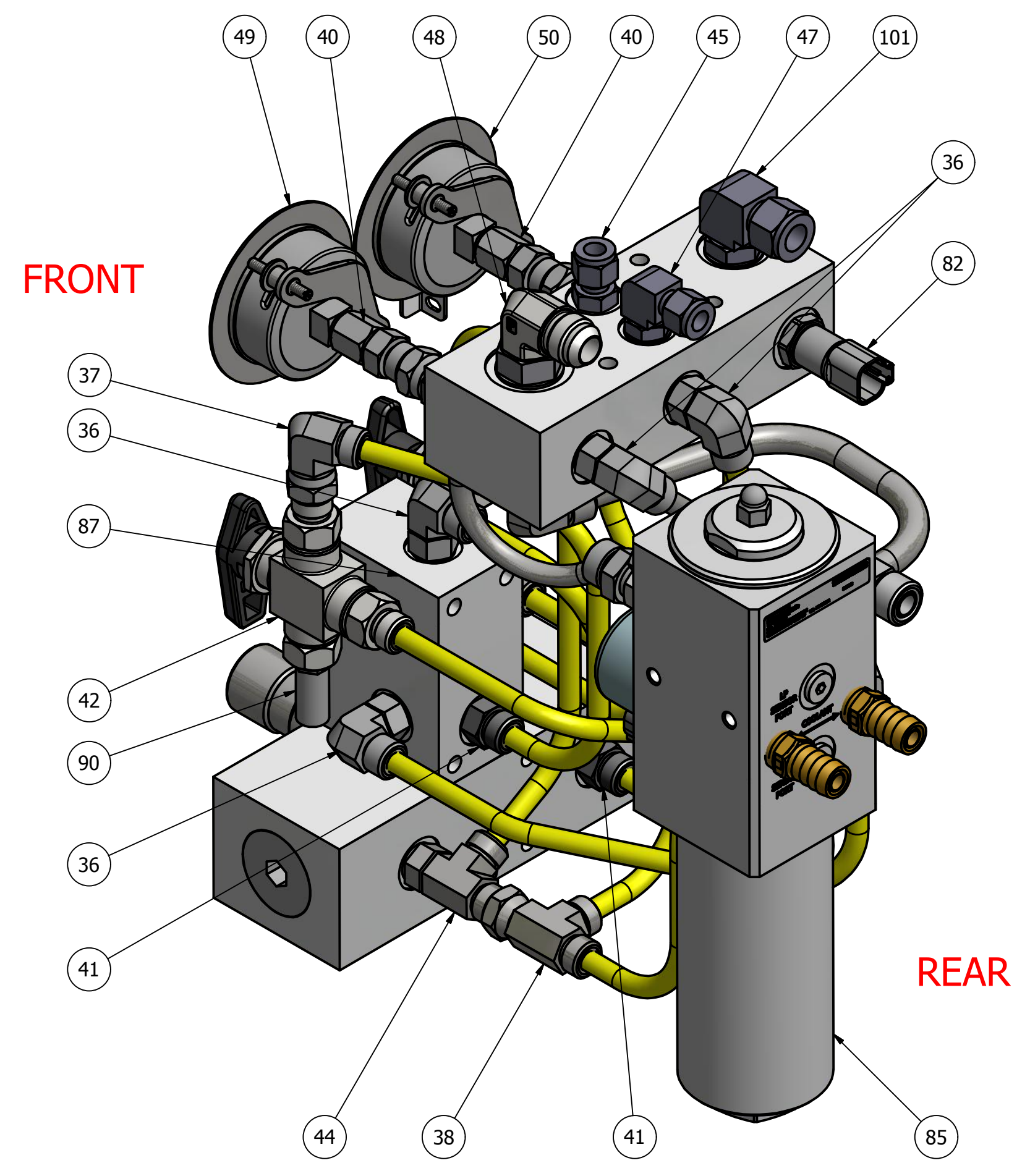

FRONT

REAR

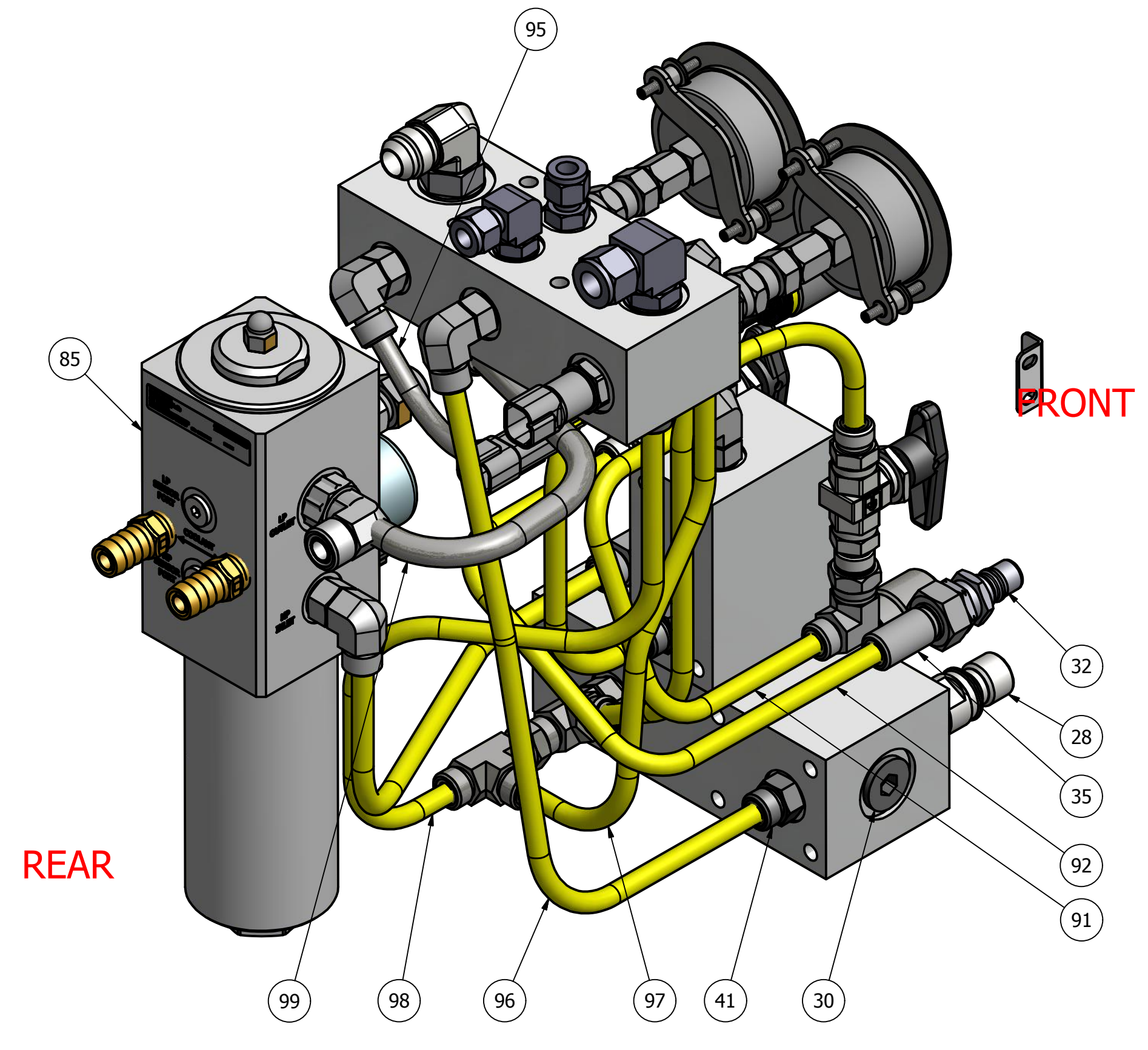

REAR

FRONT

PRELIMINARY

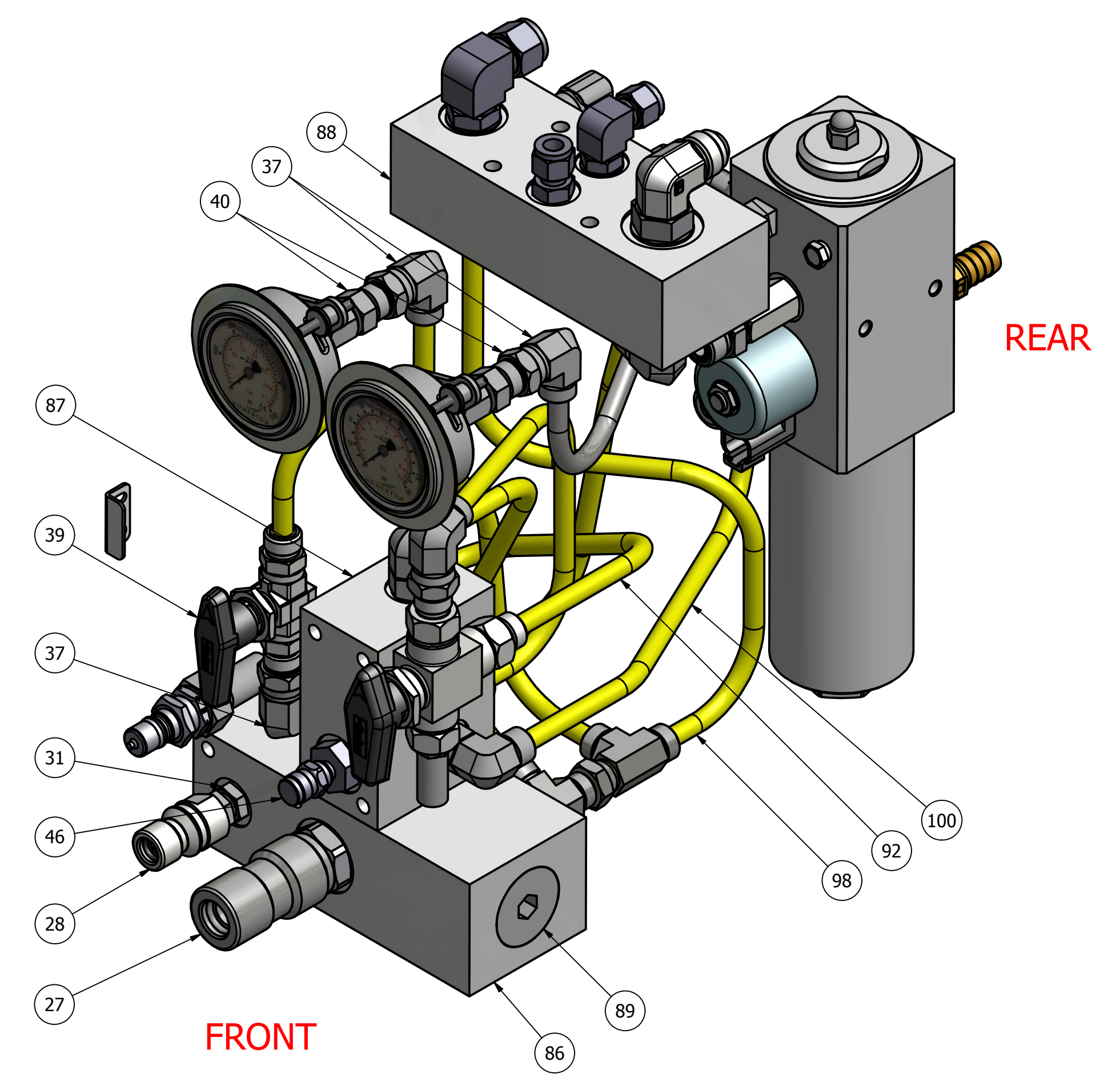

FRONT

REAR

DRAWN	KSA	11/30/2017	MOMENTUM FUEL TECHNOLOGIES 1051 Republic Drive, Suite 200 Roanoke, TX 76262	
CHECKED			TITLE	
QA			INNER PARTS MARKED	
MFG			SIZE	DWG NO
APPROVED			D	MN39-1610
Part Mass	N/A		SCALE	REV