

ALL DIMENSION TOLERANCES UNLESS NOTED
 ONE PLACE .X ±.06
 TWO PLACES .XX ±.03
 THREE PLACES .XXX ±.010
 FOUR PLACES .XXXX ±.0010
 ANGLES ±1.0°
 ALL MACHINED SURFACES TO BE 250 RMS UNLESS NOTED.

- NOTES:
- 1) FOR INFORMATION NOT CONTAINED IN THIS PRINT REFERENCE THE MATH DATA FOR THIS PART (MN39-1624)
 - 2) ALL DIMENSIONS ARE IN INCHES
 - 3) PART SHALL BE FREE OF BURRS, FLASH AND SHARP EDGES
 - 4) PART NUMBER, REV LEVEL, AND SUPPLIER CODE REQUIRED ON ALL PARTS. REFER TO DRAWING FOR SPECIFIC LOCATION, WHERE APPLICABLE. ETCH, STAMP, OR OTHERWISE PERMANENTLY ATTACH REQUIRED INFORMATION ON LARGER PARTS. PERMANENT MARKINGS SHALL BE PLACED IN SUCH A WAY THAT THEY ARE VISIBLE AFTER PART IS COATED OR PAINTED. SMALLER PARTS SHOULD HAVE THE INFORMATION ATTACHED BY THE BEST METHOD POSSIBLE. ALTERNATE MEANS OF ATTACHING INFORMATION MUST BE APPROVED.

CONFIDENTIAL AND TRADE SECRET INFORMATION OF NATURAL GAS FUEL SYSTEMS, INC. dba MOMENTUM FUEL TECHNOLOGIES
 This document and the information in it is confidential, proprietary and trade secret information of Natural Gas Fuel Systems, Inc. dba Momentum Fuel Technologies on behalf of itself and its subsidiaries and affiliates ("Momentum"). It contains information intended only for the person to whom it is transmitted and may not be disclosed to any third party, in whole or in part, or used to manufacture anything shown or referred to herein, without Momentum's express, written permission. This document must be returned to Momentum on request.

Any form of reproduction, dissemination, copying, disclosure, modification, distribution, and or publication of this document and the information contained herein is strictly prohibited.

This notice must appear on any complete or partial reproduction of this document or the information contained herein.

Copyright © 2016 Natural Gas Fuel Systems, Inc. dba Momentum Fuel Technologies. All rights reserved.

PRELIMINARY

I

DO NOT SCALE THIS PRINT

DRAWN strouhala	3/13/2020	MOMENTUM FUEL TECHNOLOGIES 1051 Republic Drive, Suite 200 Roanoke, TX 76262	
CHECKED		TITLE FMM - STAND ALONE, DUAL REMOTE, VERTICAL, MOMENTUM, SWAGELOK GAUGES	
QA		SIZE D	DWG NO MN39-1624
MFG		SCALE	REV
APPROVED			
Part Mass N/A			

CALLOUTS FOR FABRICATED AND BOUGHT COMPONENTS EXCLUDING: TUBES, FASTENERS, DOORS AND COVERS

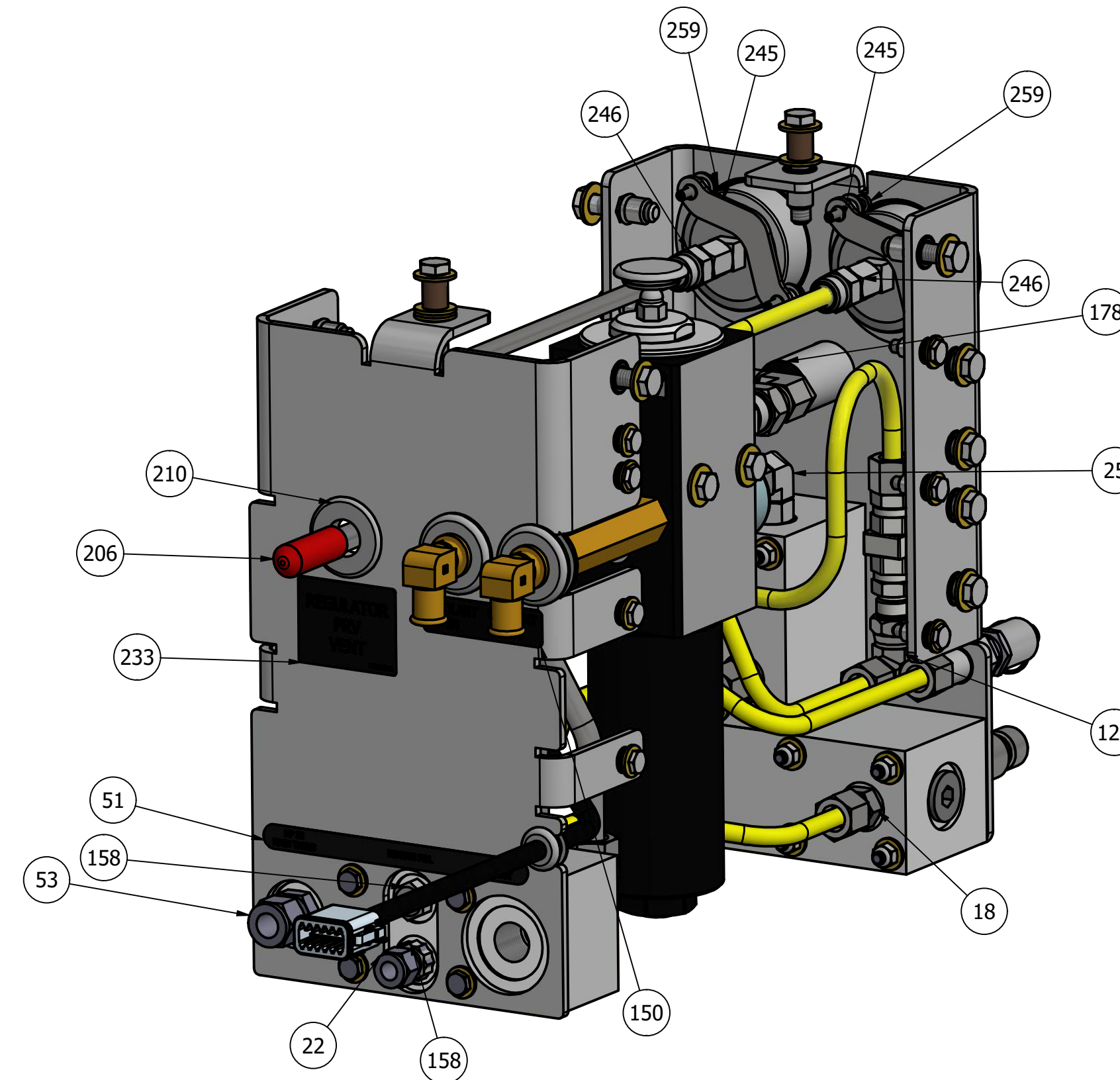
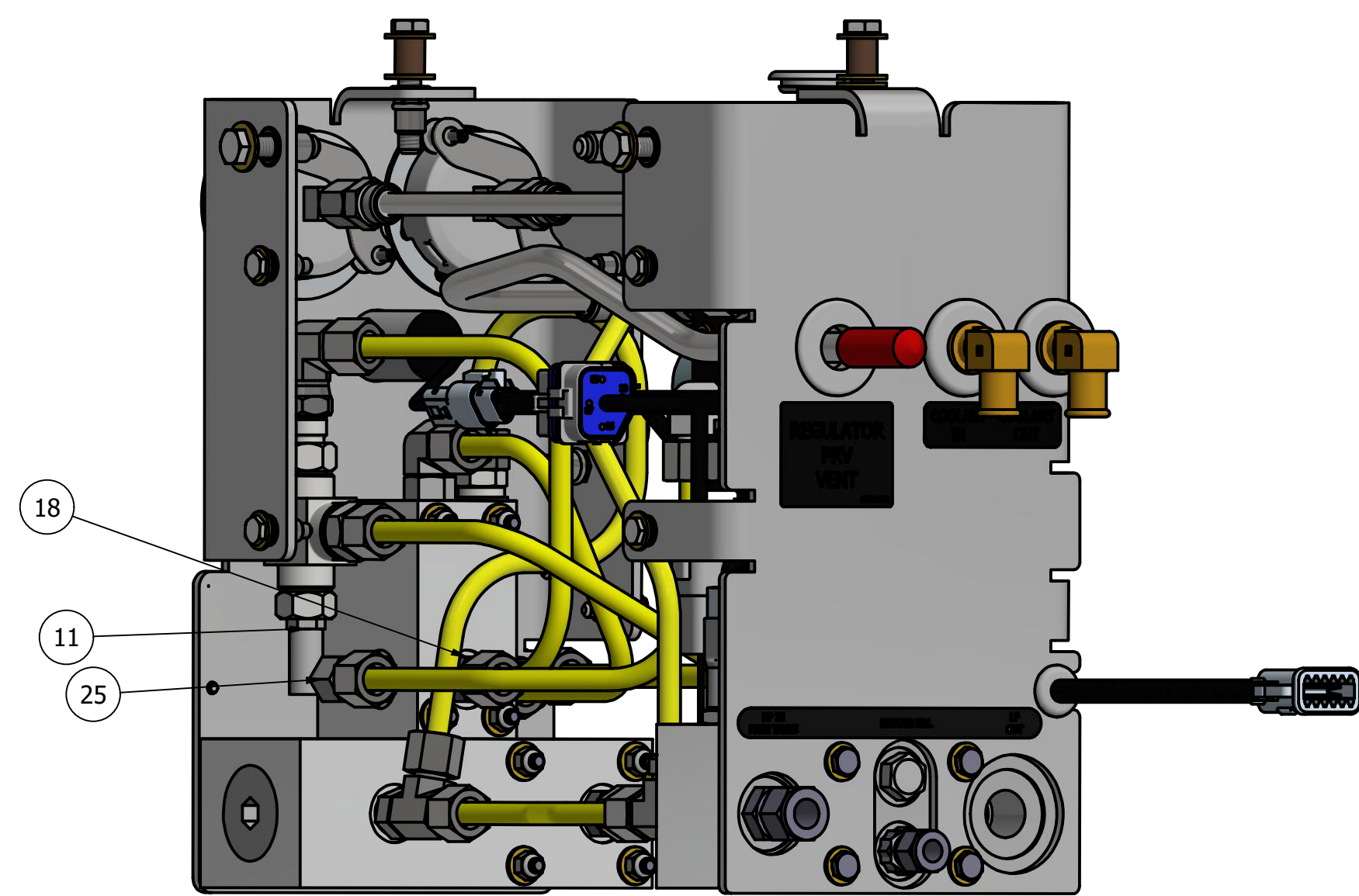
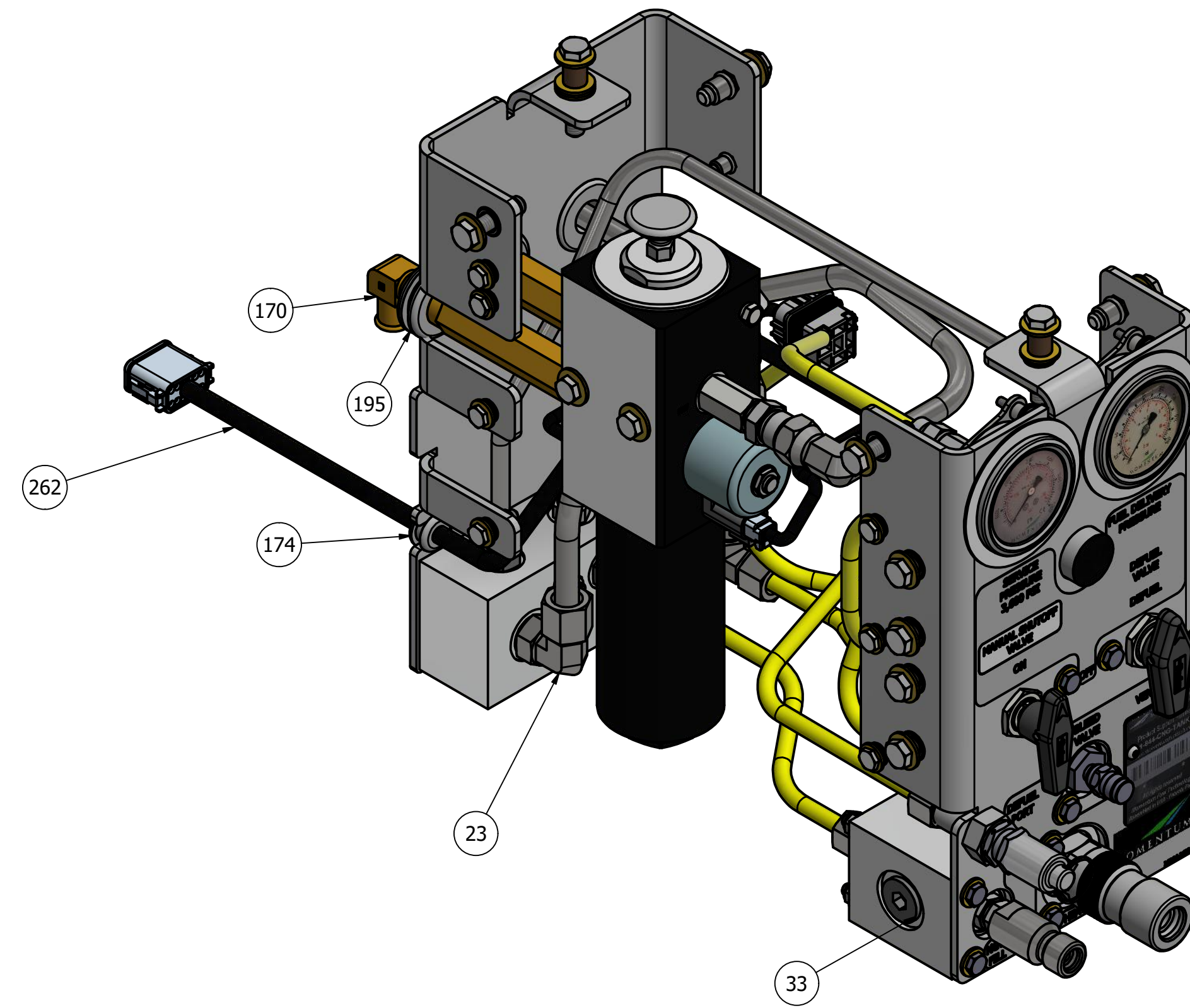
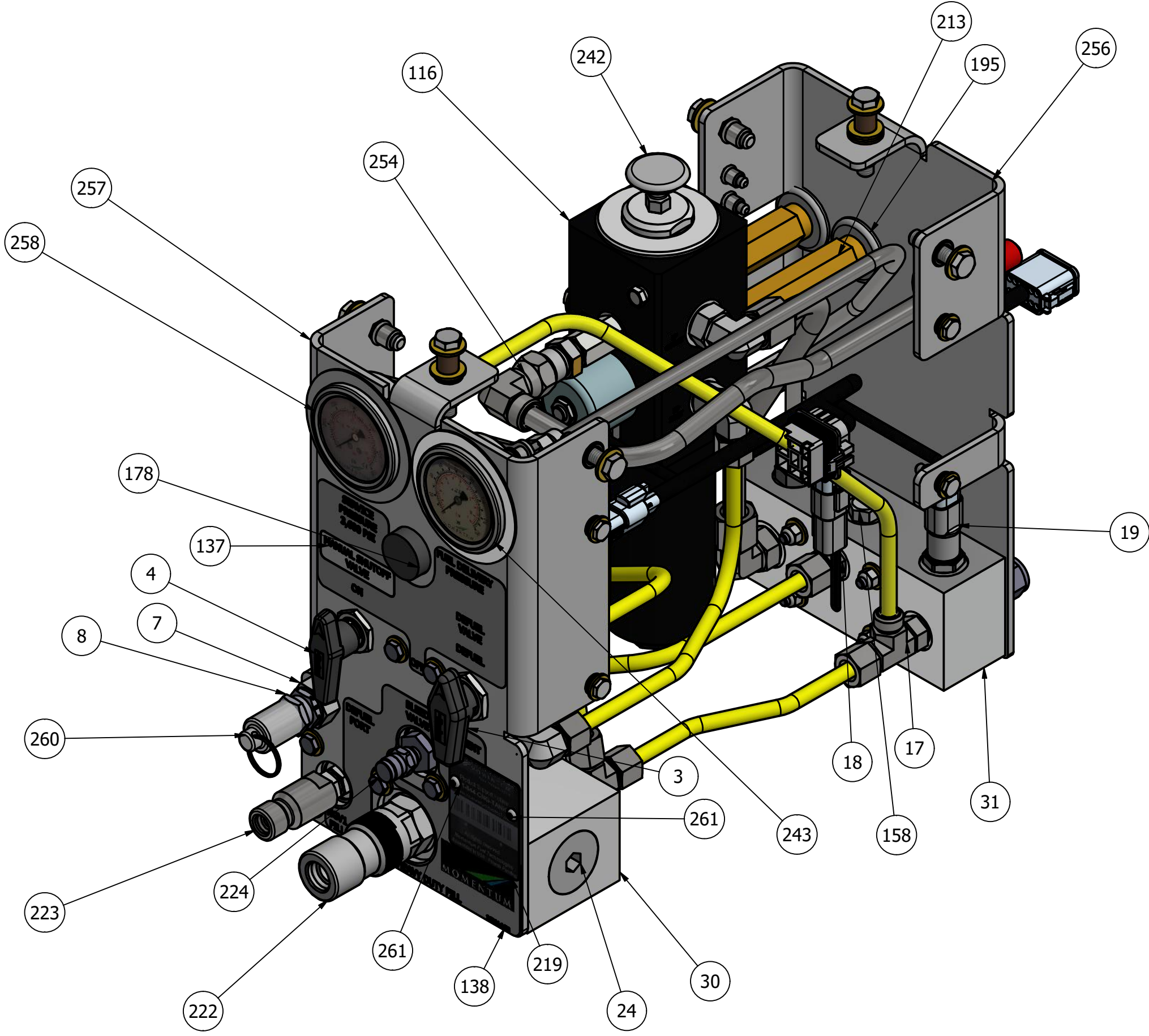

DRAWN strouhala	3/13/2020	 MOMENTUM FUEL TECHNOLOGIES 1051 Republic Drive, Suite 200 Roanoke, TX 76262	
CHECKED		TITLE	
QA		FMM - STAND ALONE, DUAL REMOTE, VERTICAL, MOMENTUM, SWAGELOK GAUGES	
MFG			
APPROVED			
Part Mass N/A		SIZE D	DWG NO MN39-1624
		SCALE	REV

CALLOUTS FOR TUBING

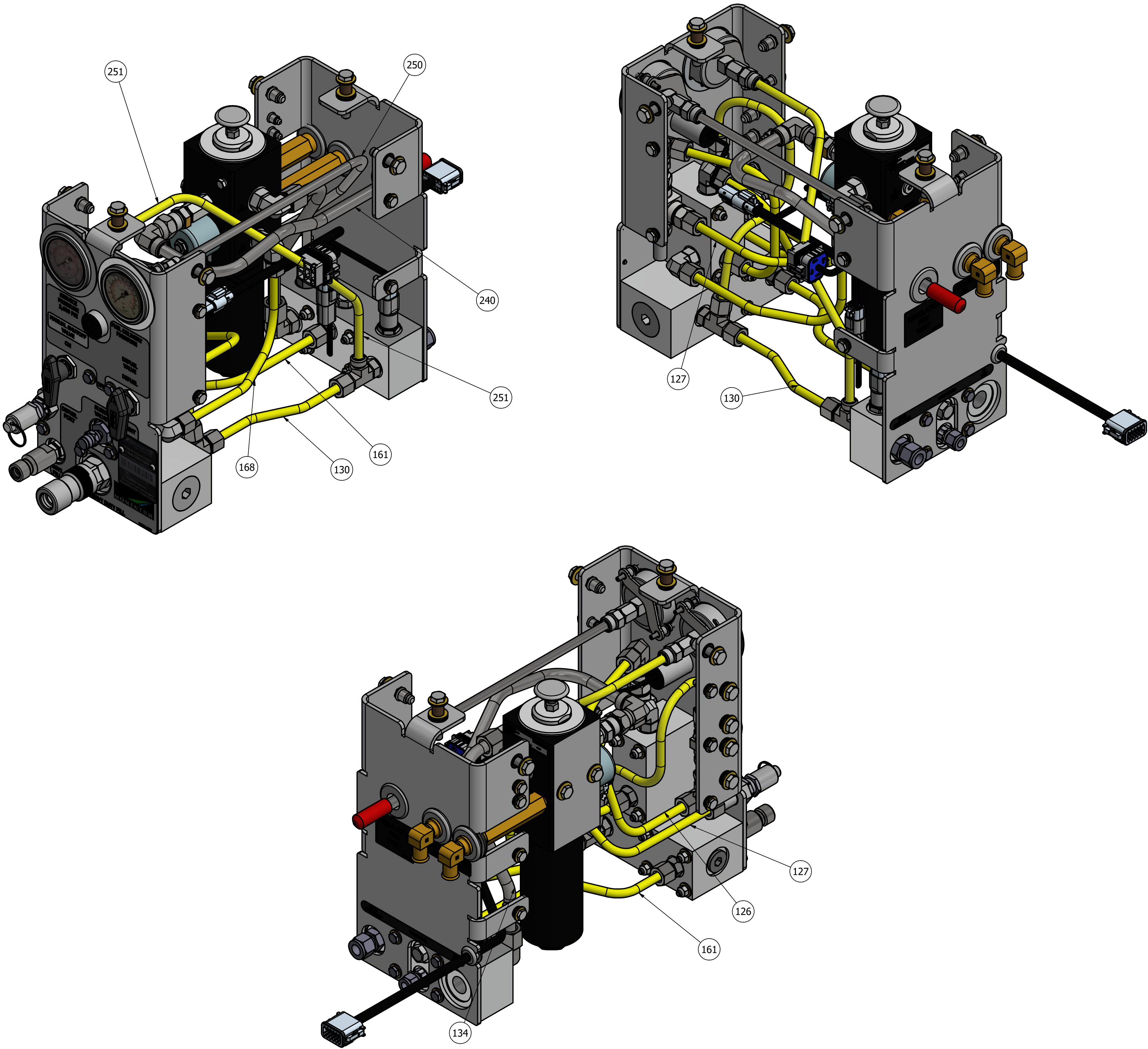

DRAWN struhala	3/13/2020	MOMENTUM FUEL TECHNOLOGIES 1051 Republic Drive, Suite 200 Roanoke, TX 76262	
CHECKED		TITLE FMM - STAND ALONE, DUAL REMOTE, VERTICAL, MOMENTUM, SWAGELOK GAUGES	
QA		SIZE D	DWG NO MN39-1624
MFG		SCALE	REV
APPROVED			
Part Mass N/A			

CALLOUTS FOR NON PANEL/DOOR FASTENERS

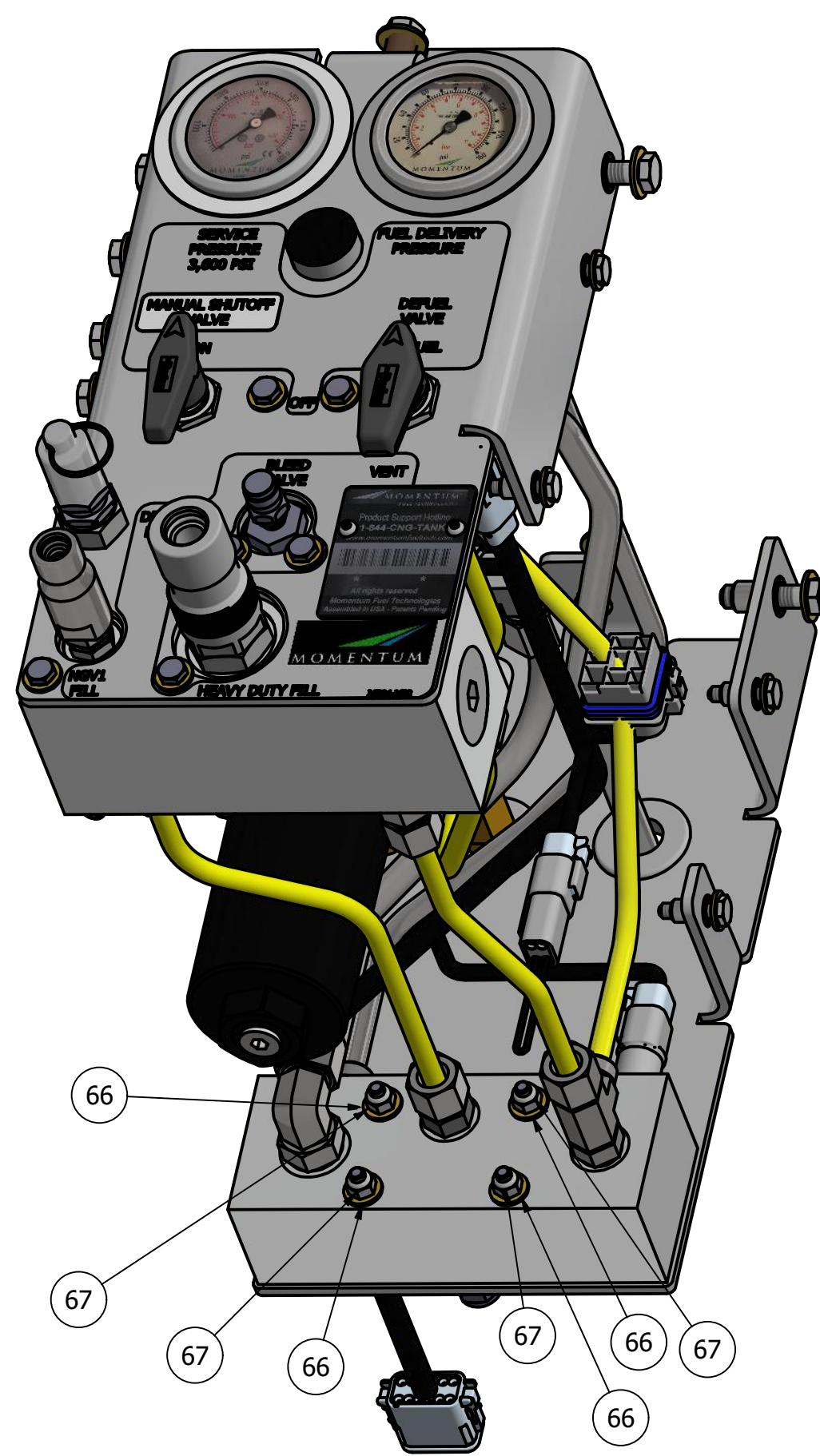
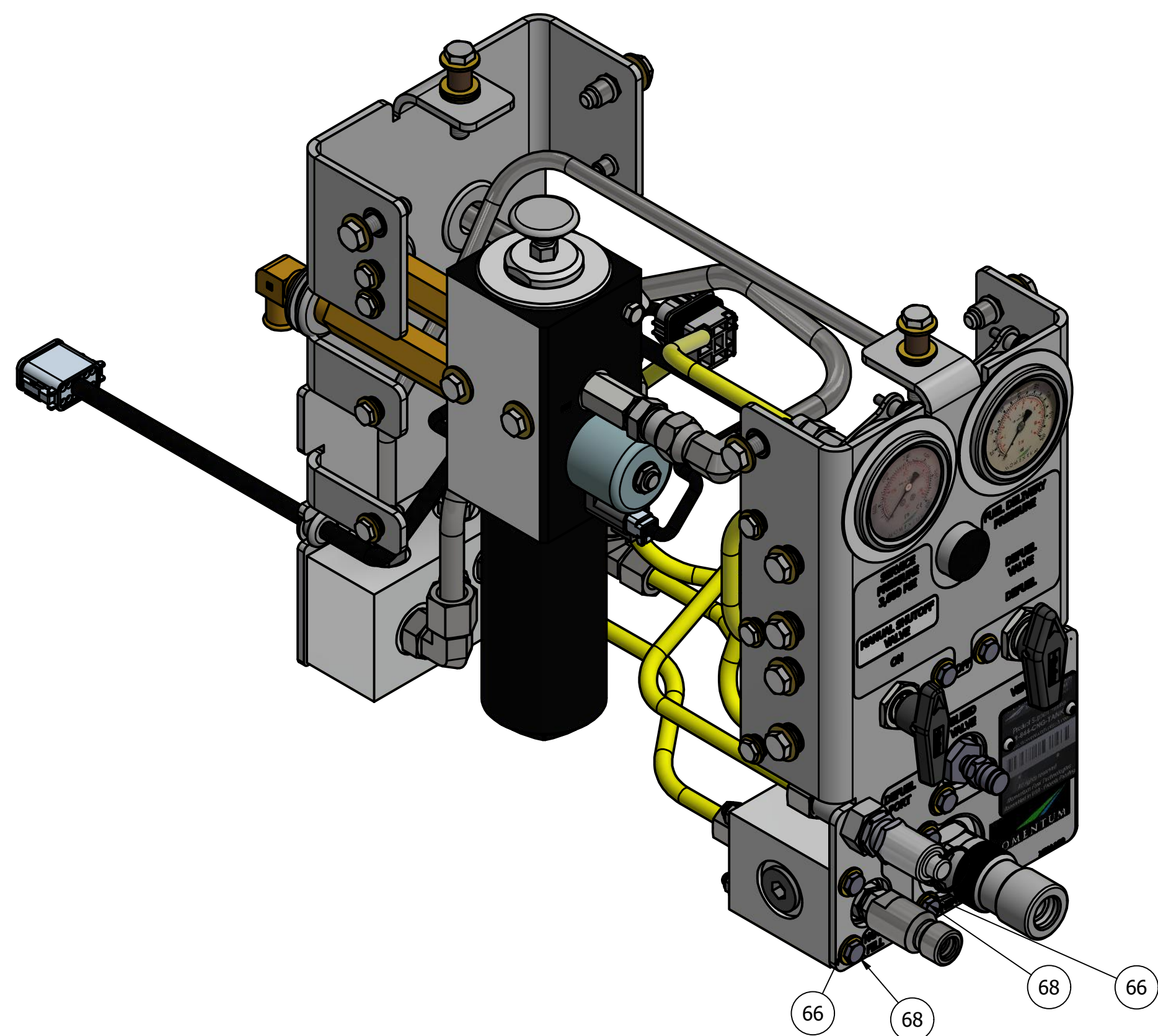
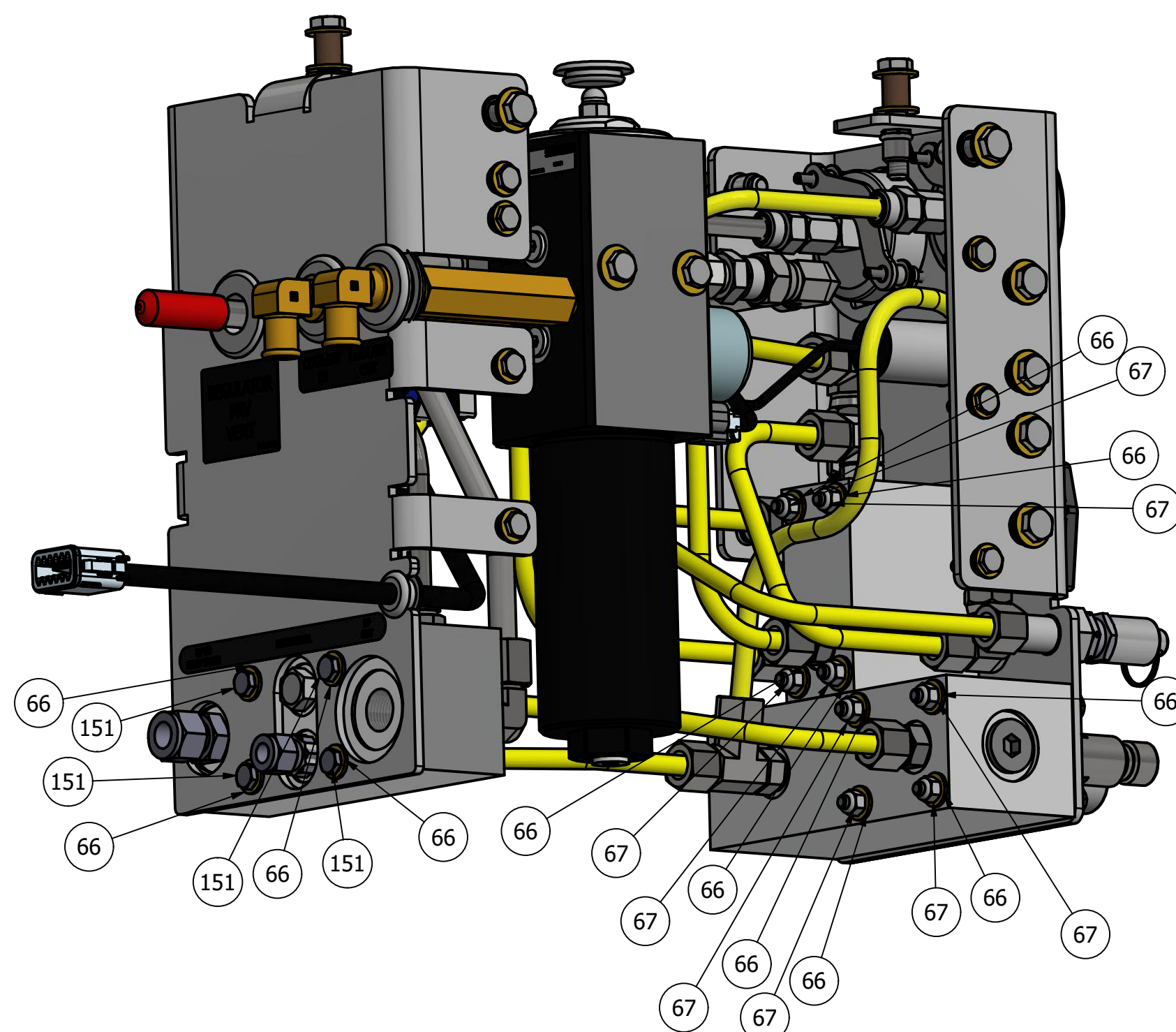
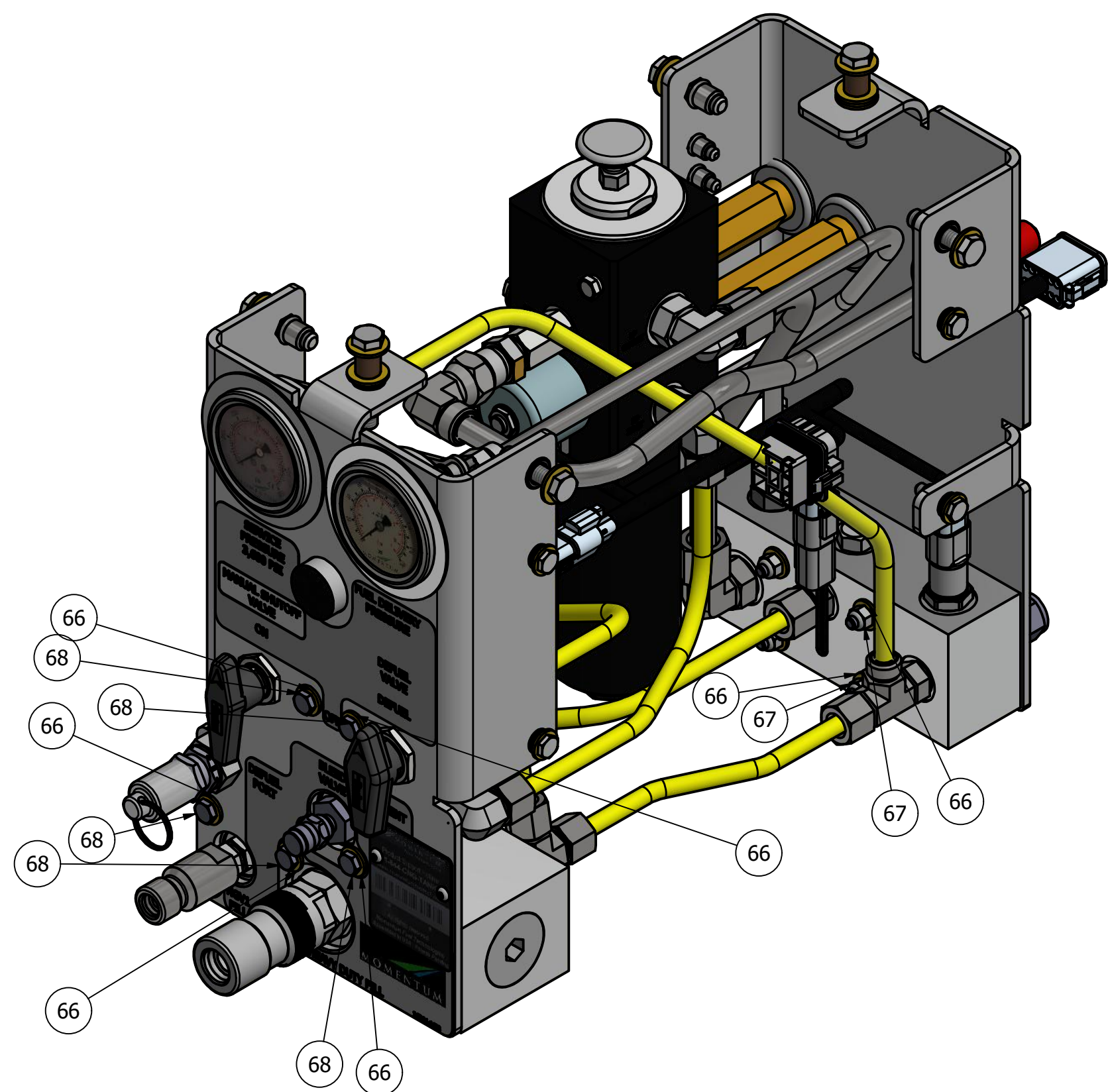

DRAWN strouhala	3/13/2020	 MOMENTUM FUEL TECHNOLOGIES 1051 Republic Drive, Suite 200 Roanoke, TX 76262	
CHECKED		TITLE	
QA		FMM - STAND ALONE, DUAL REMOTE, VERTICAL, MOMENTUM, SWAGelok GAUGES	
MFG		DWG NO	
APPROVED		MN39-1624	
Part Mass N/A		SCALE	REV

CALLOUTS FOR PANELS, HINGES, DOORS,
AND RELEVANT FASTENERS

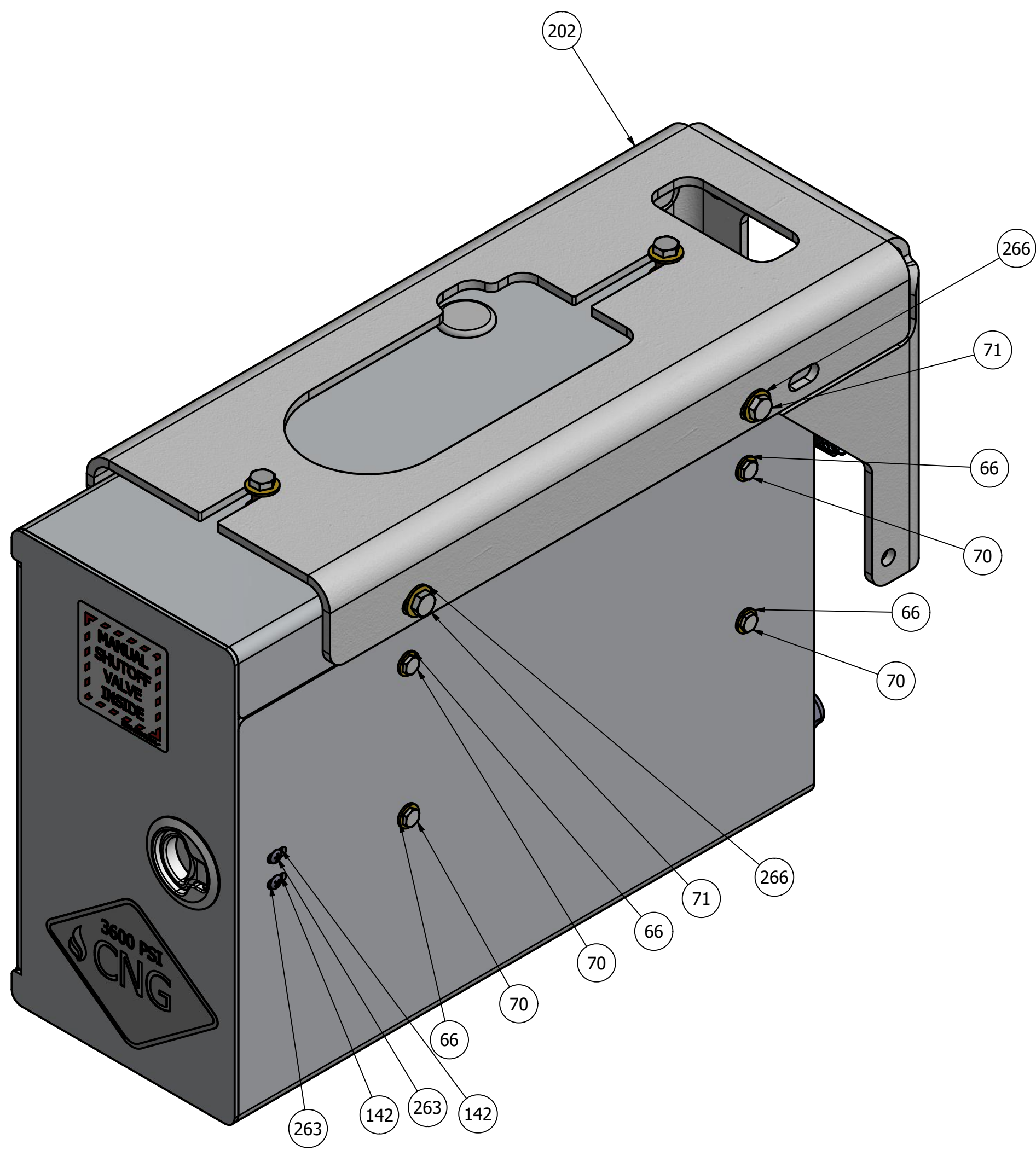
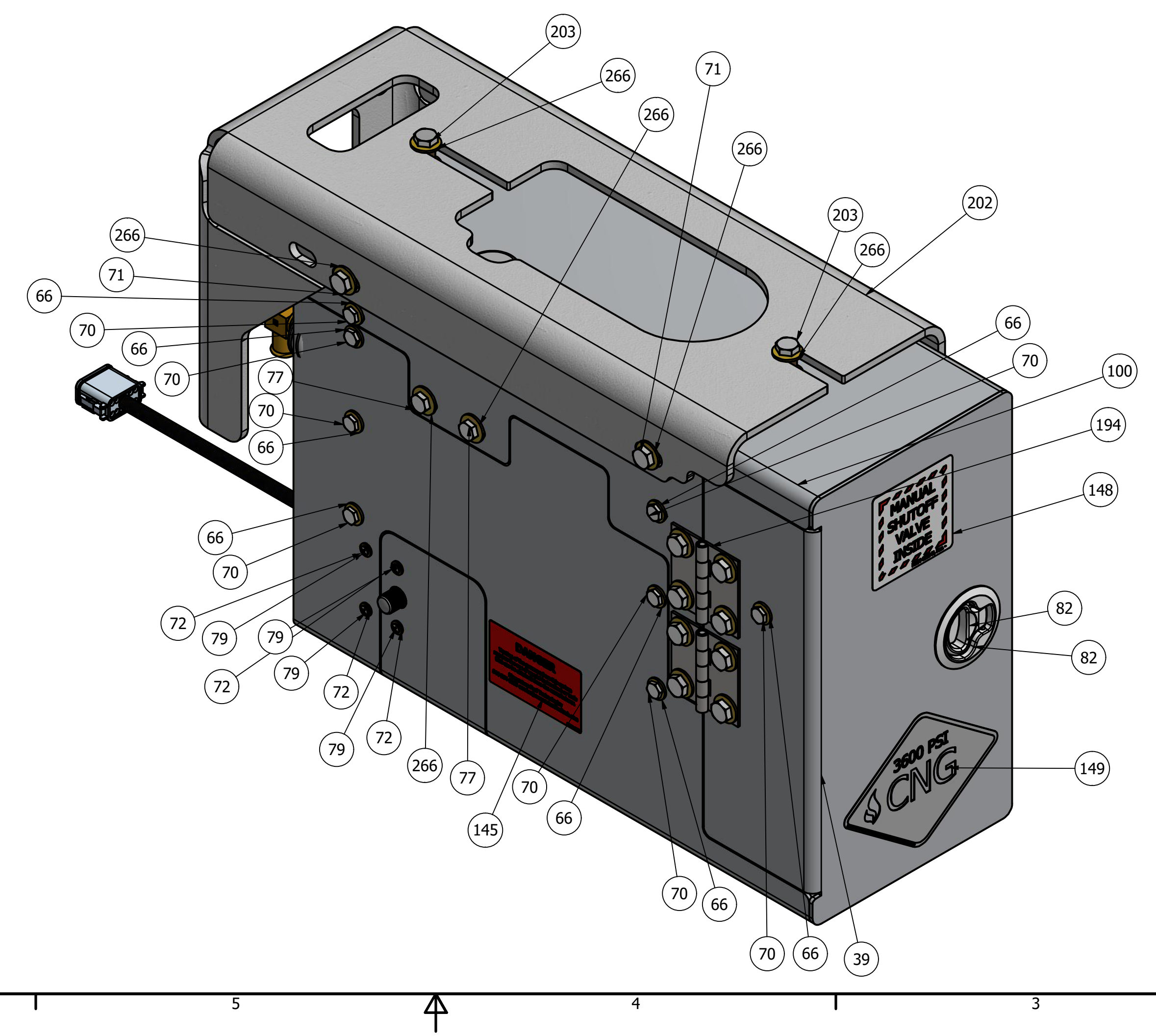
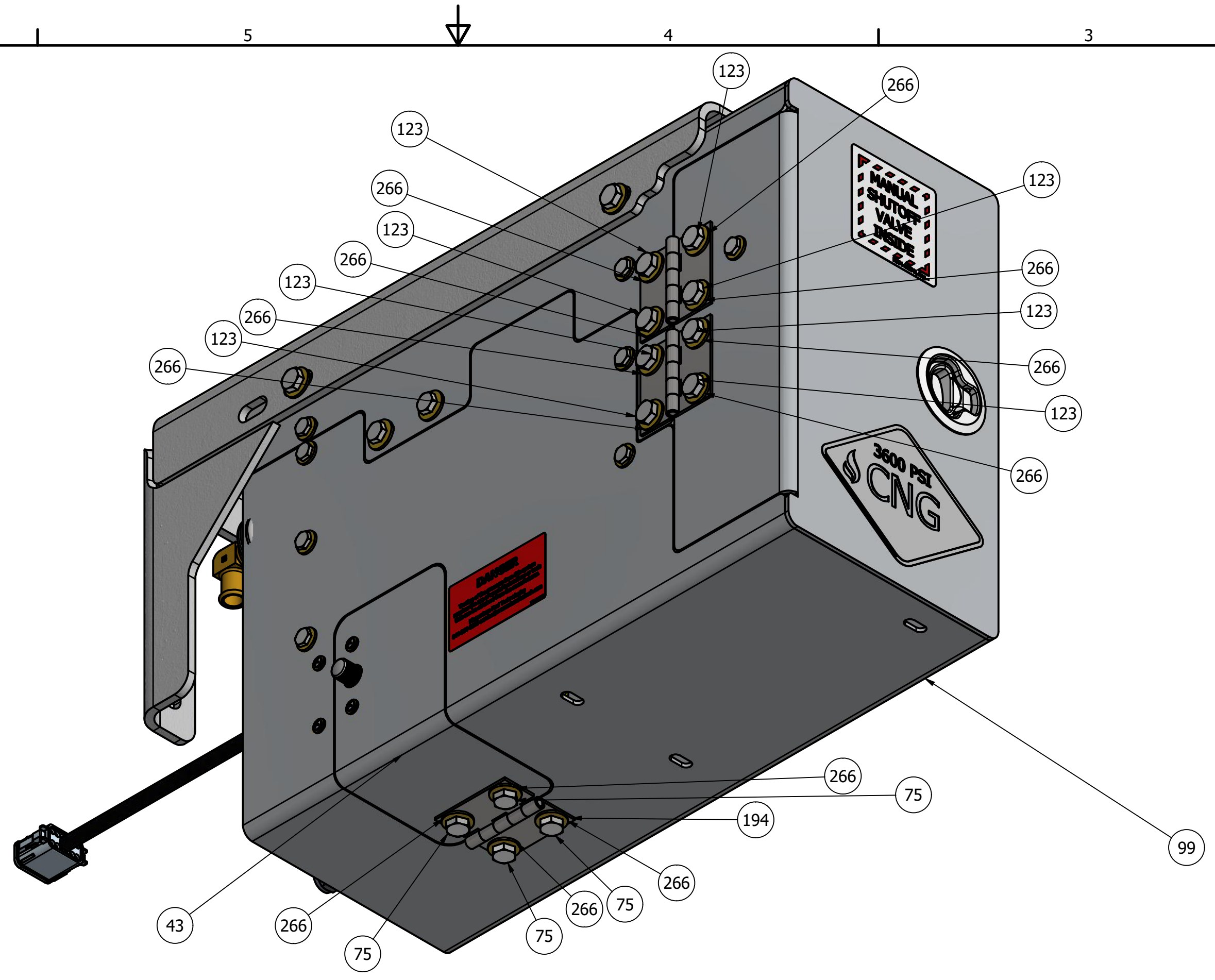

DRAWN strouhala	3/13/2020	MOMENTUM FUEL TECHNOLOGIES 1051 Republic Drive, Suite 200 Roanoke, TX 76262	
CHECKED		TITLE FMM - STAND ALONE, DUAL REMOTE, VERTICAL, MOMENTUM, SWAGELOK GAUGES	
QA		SIZE	REV
MFG		D	
APPROVED		DWG NO	
Part Mass N/A		MN39-1624	
		SCALE	SHEET 5 OF 6

ITEM	QTY	PART NUMBER	DESCRIPTION
3	1	MF17-1163-N	VALVE - 3 WAY, #6 ORFS X #6 ORFS X 1/4" NPT (RATED FOR 6,000 PSI MIN)
4	1	MF17-1031	VALVE - 2 WAY, -6 ORFS
7	1	MF17-1018	ADAPTER - BULKHEAD - STRAIGHT - #6 ORFS X #6 ORING BOSS
8	1	MF17-1007	DEFUEL NIPPLE - 316SS -6 SAE CNG
10	1	MF17-1004	FITTING - UNION - STRAIGHT - #6 ORING X # 6 ORING (9/16"-18)
11	1	MT15-1001	MUFFLER - STEEL 1/4" NPT - 105 SCFM 1-3/4 HEIGHT
17	2	MF17-1185-N	ADAPTER - TEE, RUN #6 STANDARD ORING BOSS (MALE) X #8 ORFS (MALE) X #8 ORFS (MALE)
18	4	MF17-1149-N	ADAPTER - #6 ORFS (MALE) X #6 ORING BOSS (MALE)
19	1	MP15-1003	TRANSDUCER, PRESSURE
22	1	MF17-1186-N	CONNECTOR-MALE, 9/16-18 #6 MALE ORB X 3/8" TUBE
23	1	MF17-1013	ELBOW - 90° 1/2" STANDARD O-RING X 1/2" ORFS (O-RING FACE SEAL)
24	1	MS15-1001	VALVE_CARTRIDGE_CHECK
25	2	MF17-1019	ADAPTER - 90° ELBOW - #6 ORING BOSS X #6 ORFS
29	4	MH27-1010	NUT - HALF HEX RIVET, 3/8"-16, GRADE 5, (GRIP RANGE 0.150" - 0.312")
30	1	MS12-1104-N	MANIFOLD-FRONT FILL, VERTICAL FMM
31	1	MS12-1107-N	MANIFOLD - REAR FUEL, DUAL REMOTE FILL
32	1	MS12-1106-N	
33	1	MF14-1101-N	#10 ORING BOSS HOLLOW HEX PLUG
39	1	MC07-1147-N	COVER - FRONT DOOR, VERTICAL FMM
41	1	MH27-1009	NUT - HALF HEX RIVET - 1/4"-20 (GRIP RANGE 0.165-0.260)
43	1	MC07-1145-N	COVER - FILTER DOOR, VERTICAL FMM
46	1	MK32-1103-N	LATCH - PANEL, MEDIUM, KNURLED HEAD, STAINLESS STEEL
50	1	MD04-1900	BRACKET - PROX TARGET, VERTICAL FMM
51	1	MB34-1173-N	DECAL - FMM - STAND ALONE
53	1	MF17-1187-N	ADAPTER - MALE, 1/2" TUBE SWAGelok x 3/14"-16 #8 ORB MALE
66	36	MH27-1004-004-FL-YZ-008	WASHER - FLAT, #6, SS
67	12	MH27-1003-004-20-YZ-008-NL	
68	8	MH27-1001-004-20-375-YZ-008-HH	BOLT - HEX HEAD, 1/4"-20 X 3-3/4" LONG, GRADE 8, YELLOW ZINC
70	12	MH27-1001-004-20-100-YZ-008-HH	
71	4	MH27-1001-006-16-150-YZ-008-HH	
72	9	MH27-1004-M06-FL-SS-008	WASHER - FLAT, #6, STAINLESS STEEL GRADE 8
75	4	MH27-1001-006-16-100-YZ-008-HH	
76	4	MH27-1003-006-16-YZ-008-NL	NUT - NYLON LOCKING, 5/16"-18, YELLOW ZINC GRADE 8
77	2	MH27-1002-M08-125-020-YZ-109-HH	
79	4	MH27-1001-M06-32-075-SS-188-BH	SCREW- BUTTON HEAD, #6-32 X 3/4" LONG, 18-8 STAINLESS STEEL
82	1	Southco-M1-61-8	
99	1	MC06-1796	COVER - BOTTOM, VERTICAL FMM
100	1	MC06-1797	COVER - TOP, VERTICAL FMM
116	1	MR15-1603	REGULATOR-CNG, PARKER F80 VERIFLO LH CONFIGURATION
123	8	MH27-1001-006-16-125-YZ-008-HH	
125	2	MF17-1024	FITTING - 90° ELBOW-6 ORFS MALE X -6 ORFS FEMALE SWIVEL
126	10.017 in	MT21-1497-YELLOW	Tube- 3/8", SHUTOFF VALVE OUTLET TO MANIFOLD,VERT.FMM
127	14.155 in	MT21-1498-YELLOW	TUBE- 3/8", DEFUEL VALVE COMMON TO DEFUEL COUPLING, VERT.FMM
130	7.333 in	MT21-1501-YELLOW	Tube- 3/8", TO TANKS, VERT.FMM
134	10.219 in	MT21-1505-N	Tube- 1/2", REGULATOR OUTLET TO MANIFOLD, VERT.FMM

ITEM	QTY	PART NUMBER	DESCRIPTION
137	1	MB34-1171-N	DECAL - FMM - STAND ALONE
138	1	MB34-1622	DECAL - FMM - STAND ALONE
142	4	MH27-1004-M10-FL-ZN	WASHER - FLAT, #10, ZINC
144	2	MH27-1003-M10-24-ZN-002-NL	NUT - NYLON LOCKING, #10-24, ZINC GRADE 2
145	2	MB34-1003	
148	1	MB34-1135-N	
149	1	MB34-1100-N	
150	1	MB34-1176-N	
151	4	MH27-1001-004-20-275-YZ-008-HH	BOLT - HEX HEAD, 1/4"-20 X 2-3/4" LONG, GRADE 8, YELLOW ZINC
154	1	MC06-1188-N	
157	1	MB34-1015	
158	3	MF14-1004	PLUG - #6 ORING BOSS
161	10.463 in	MT21-1510-YELLOW	Tube- 3/8", AUX FILL, VERTICAL FMM
168	10.745 in	MT21-1500-YELLOW	Tube-3/8", MANIFOLD TO REGULATOR INLET, VERTICAL FMM
169	11.088 in	MT21-1504-YELLOW	Tube-3/8", MANIFOLD TO DEFUEL VALVE INLET, VERTICAL FMM
170	2	MF17-1188-N	ADAPTER - 90° ELBOW 3/8" NPT (MALE) X 5/8" HOSE BARB (MALE)
174	1	MH24-1601	3/8" ID X 7/8" OD RUBBER GROMMET
178	1	MP15-1101-N	PROX SENSOR - INDUCTIVE, 30MM DIA, PNP, NO
190	2	MF17-1027	NUT 1/2" ORFS
191	14	MF17-1029	NUT 3/8" ORFS
194	3	MK08-1000	ACCESSORIES - HINGE, BUTT
195	2	MH24-1604	7/8" ID X 1-5/8" OD RUBBER GROMMET, 3/16" PANEL THICKNESS
202	1	MD04-1810	BRACKET - MOUNTING, VERTICAL FMM
203	2	MH27-1001-006-16-200-YZ-008-HH	
204	2	MD04-1868	SPACER - FMM BRACKET
206	1	AT18-1000	VENT CAP - AFTERMARKET, PRD, RED, SLIP-ON
210	1	MH24-1606	1/2" ID X 1-1/2" OD RUBBER GROMMET, 3/16" PANEL THICKNESS
213	2	MF17-1637	ADAPTER, STRAIGHT, BRASS 3/8" NPT X 5/8" HOSE BARB
219	1	MB34-1635	DECAL - SERIAL TAG, FRONT PANEL
222	1	MF13-1102-N	
223	1	MF13-1103-N	RECEPTACLE - NGV1 FILL (INCLUDES DUST CAP) - (#6 SAE O-RING FEMALE)
224	1	MF17-1610	PURGE VALVE WITH SS BALL
233	1	MB34-1641	DECAL - FMM - STAND ALONE, HORIZONTAL, PRV VENT
237	1	MD04-1894	PLATE - BACKING, DOOR, VERTICAL FMM
240	15.071 in	MT21-1924-N	TUBE-1/2", HEIL VERTICAL FMM
242	1	MK31-1002	
243	1	MG25-1100-N	
245	2	MG25-1102-N	
246	2	MF17-1141-N	ADAPTER - STRAIGHT #6 (3/8") ORFS X #6 (3/8") TUBE
250	20.538 in	MT21-2126-N	Tube
251	17.175 in	MT21-2125-YELLOW	Tube
252	1	MF17-1194-N	ADAPTER-MALE, #10 MALE ORB X #12 MALE JIC, SS
253	1	MB34-1618	
254	1	MF17-1148-N	FITTING - 90° ELBOW-8 ORFS MALE X -8 ORFS FEMALE SWIVEL
256	1	MC06-1926	ASSEMBLY - PANEL, BACK, VERTICAL FMM w/RIVET NUTS
257	1	MD04-1980	
258	1	MG25-1607	GAUGE, 0-6000 PSI, 2.5" DIAMETER PANEL MOUNT, SILICONE FILED, 3/8" TUBE STUB CENTER BACK CONNECTION
259	2	MG04-1600	SUPPORT - GAUGE MOUNT
260	1	MF17-1621	
261	2	MH27-1619	
262	1	MP92-1037	Harness-Stand Alone FMM
263	2	MH27-1001-M10-24-075-SS-188-PH	
264	4	MH27-1003-M06-32-SS-008-NL	
265	14.911 in	MT21-2452-YELLOW	Tube
266	27	MH27-1004-006-FL-YZ-008	WASHER - 3/8", SAE, FLAT, YZ, GR8

DRAWN	3/13/2020	 MOMENTUM FUEL TECHNOLOGIES 1051 Republic Drive, Suite 200 Roanoke, TX 76262	
CHECKED		TITLE	
QA		FMM - STAND ALONE, DUAL REMOTE, VERTICAL, MOMENTUM, SWAGelok GAUGES	
MFG			
APPROVED			
Part Mass		SIZE	REV
		D	
		DWG NO	
		MN39-1624	
		SCALE	SHEET 6 OF 6