

ZONE	REV	DESCRIPTION	DATE	APPROVED
			10/26/2016	CBC
C7	A	CHANGED ROUT OF FUEL LVL GROUND	10/26/2016	CBC
D4-5	B	CHANGED CONNECTORS ON J3 AND P2	11/8/2016	CBC

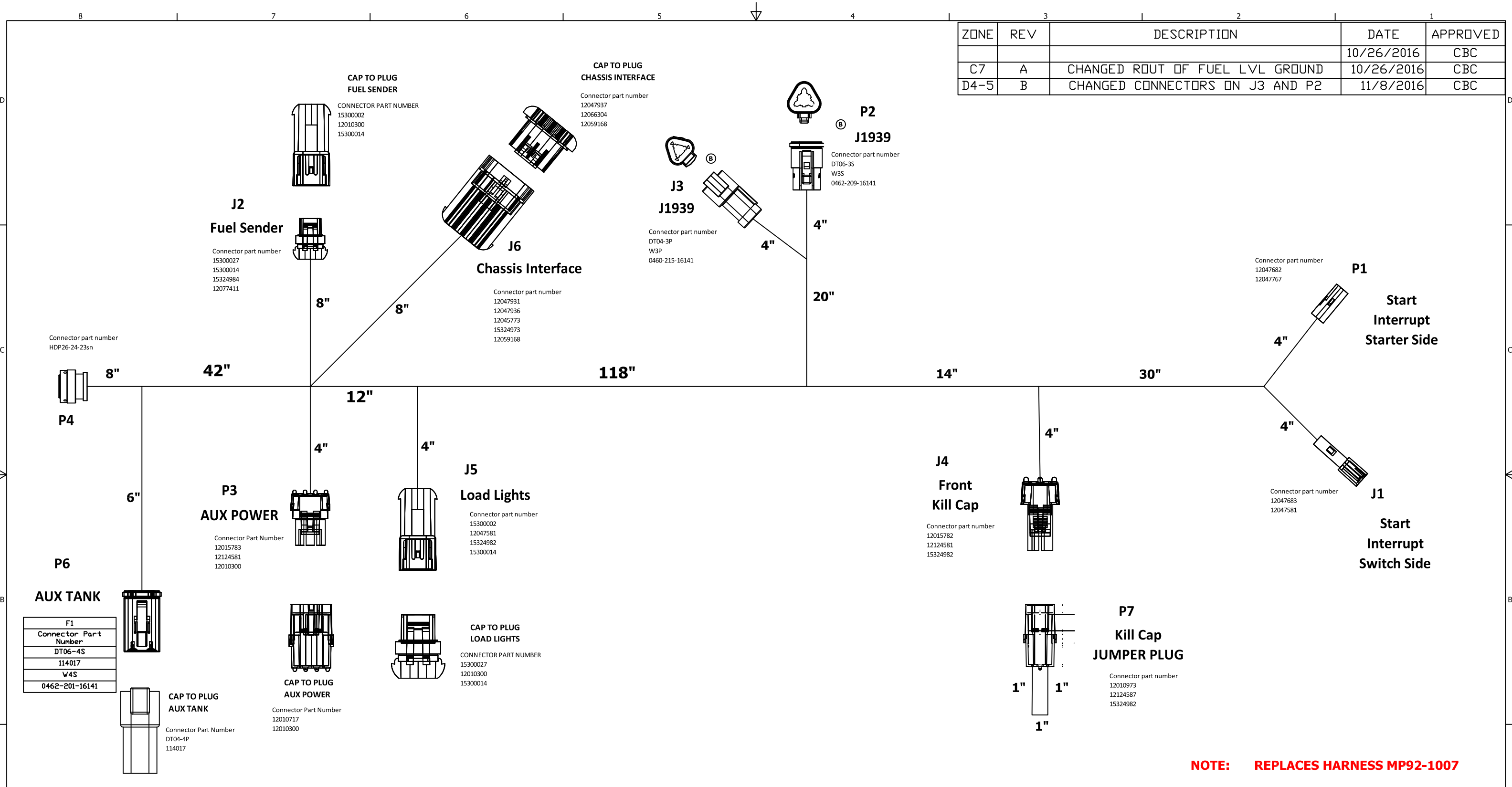

NOTE: REPLACES HARNESS MP92-1007

CONFIDENTIAL AND TRADE SECRET INFORMATION OF RUSH ENTERPRISES, INC.
This document and the information in it is confidential, proprietary and trade secret information of Rush Enterprises, Inc. and its subsidiaries ("Rush"). It contains information intended only for the person to whom it is transmitted and may not be disclosed to any third party, in whole or in part, or used to manufacture anything shown or referred to herein, without Rush's express, written permission. This document must be returned to Rush on request.

Any form of reproduction, dissemination, copying, disclosure, modification, distribution and or publication of this document and the information contained herein is strictly prohibited.

This notice must appear on any complete or partial reproduction of this document or the information contained herein.

Copyright © 2014 Rush Enterprises, Inc. All rights reserved.

ALL DIMENSION TOLERANCES UNLESS NOTED
ONE PLACE .X ±.06
TWO PLACES .XX ±.03
THREE PLACES .XXX ±.010
FOUR PLACES .XXXX ±.0010
ALL MACHINED SURFACES TO BE 250 RMS UNLESS NOTED.

I
DO NOT SCALE THIS PRINT

DRAWN brummern	9/20/2016	MOMENTUM FUEL TECHNOLOGIES 1051 Republic Drive, Suite 200 Roanoke, TX 76262	
CHECKED culbersonc	10/25/16	TITLE Harness-Chassis Interface, Peterbilt NGP Cab	
QA		SIZE D	DWG NO MP92-1022
MFG		SCALE	REV B
APPROVED			SHEET 1 OF 2
Part Mass			

ZONE	REV	DESCRIPTION	DATE	APPROVED
			10/26/2016	CBC
C7	A	CHANGED ROUT OF FUEL LVL GROUND	10/26/2016	CBC
C5	B	CHANGED CONNECTORS ON J3 AND P2	11/8/2016	CBC

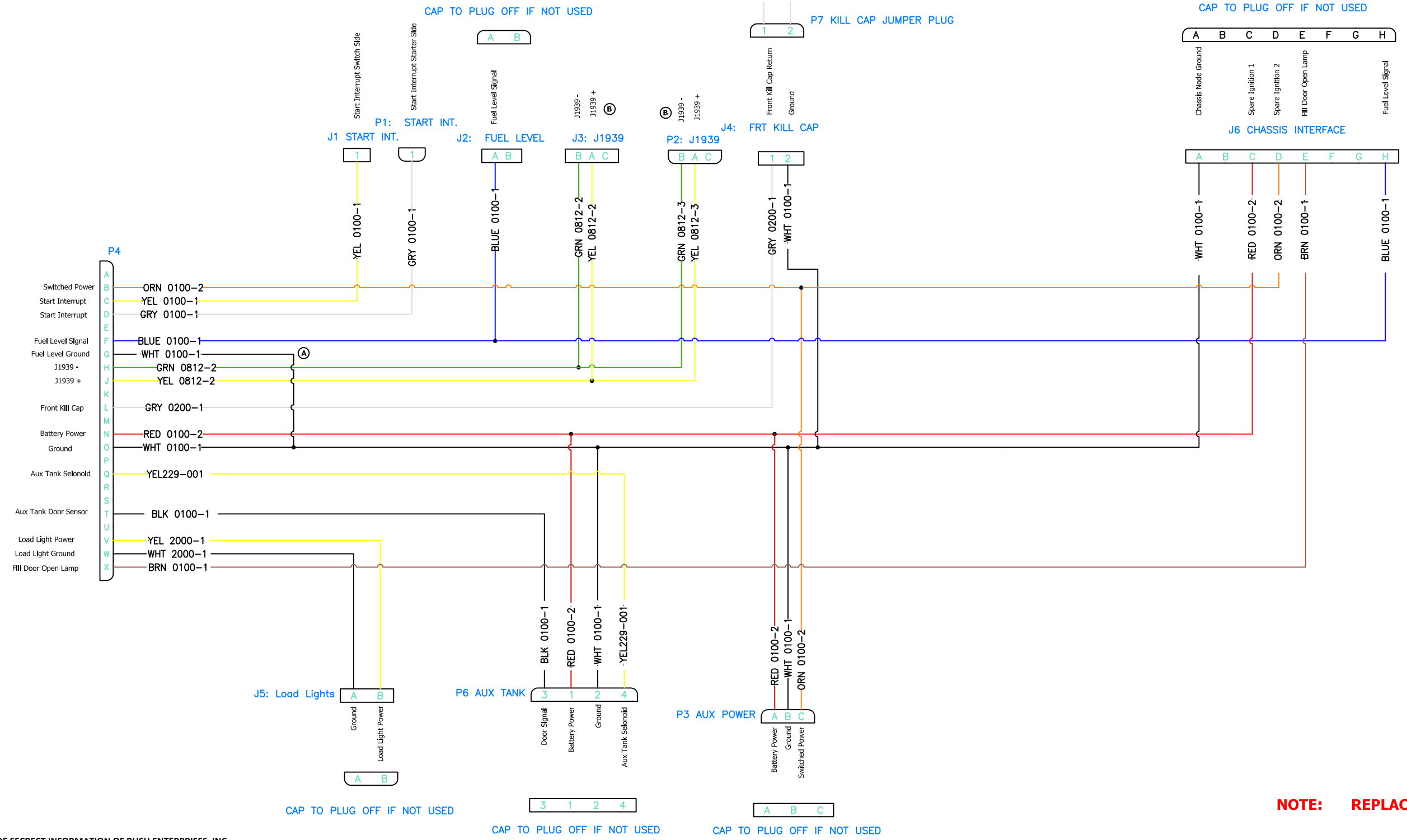

NOTE: REPLACES HARNESS MP92-1007

CONFIDENTIAL AND TRADE SECRET INFORMATION OF RUSH ENTERPRISES, INC.
 This document and the information in it is confidential, proprietary and trade secret information of Rush Enterprises, Inc. and its subsidiaries ("Rush"). It contains information intended only for the person to whom it is transmitted and may not be disclosed to any third party, in whole or in part, or used to manufacture anything shown or referred to herein, without Rush's express, written permission. This document must be returned to Rush on request.

Any form of reproduction, dissemination, copying, disclosure, modification, distribution and or publication of this document and the information contained herein is strictly prohibited.

This notice must appear on any complete or partial reproduction of this document or the information contained herein.

Copyright © 2014 Rush Enterprises, Inc. All rights reserved.

ALL DIMENSION TOLERANCES UNLESS NOTED
 ONE PLACE .X ±.06
 TWO PLACES .XX ±.03
 THREE PLACES .XXX ±.010
 FOUR PLACES .XXXX ±.0010
 ALL MACHINED SURFACES TO BE 250 RMS UNLESS NOTED.



DO NOT SCALE THIS PRINT

DRAWN brummerm	9/20/2016	MOMENTUM FUEL TECHNOLOGIES 1051 Republic Drive, Suite 200 Roanoke, TX 76262	
CHECKED culbersonc	10/26/16	TITLE Harness-Chassis Interface, Peterbilt NGP Cab	
QA		SIZE D	DWG NO MP92-1022
MFG		SCALE	REV B
APPROVED			
Part Mass			