

8 7 6 5 4 3 2 1

D

D

C

C

B

B

A

A

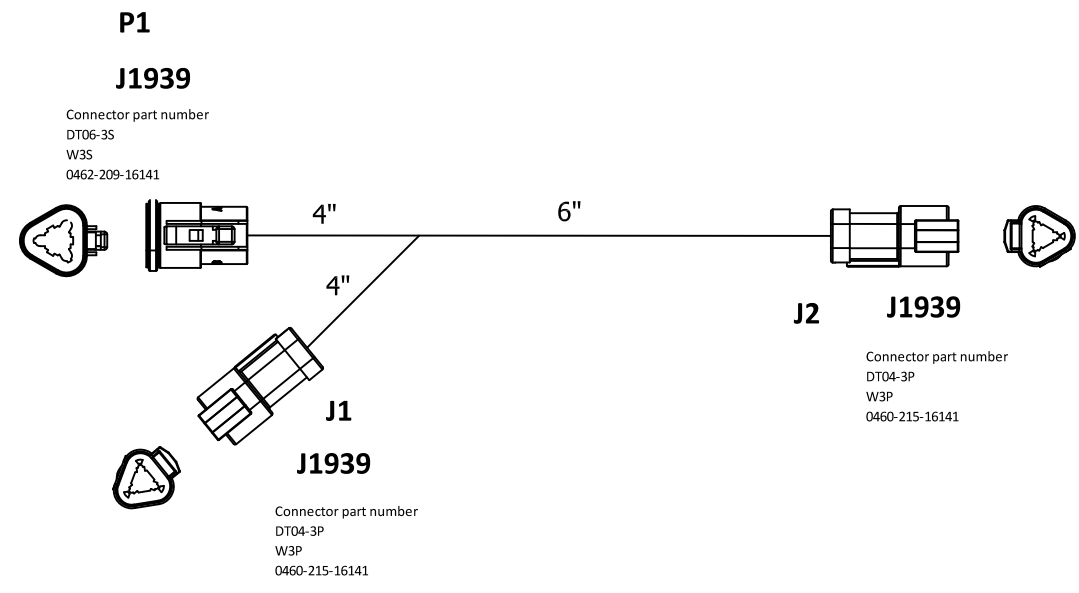

NOTES:
1. HARNESS TO BE BRAIDED WITH VN4400S OR EQUIVALENT PVC COATED YARN

CONFIDENTIAL AND TRADE SECRET INFORMATION OF NATURAL GAS FUEL SYSTEMS, INC. dba MOMENTUM FUEL TECHNOLOGIES
This document and the information in it is confidential, proprietary and trade secret information of Natural Gas Fuel Systems, Inc. dba Momentum Fuel Technologies on behalf of itself and its subsidiaries and affiliates ("Momentum"). It contains information intended only for the person to whom it is transmitted and may not be disclosed to any third party, in whole or in part, or used to manufacture anything shown or referred to herein, without Momentum's express, written permission. This document must be returned to Momentum on request.

Any form of reproduction, dissemination, copying, disclosure, modification, distribution, and or publication of this document and the information contained herein is strictly prohibited.

This notice must appear on any complete or partial reproduction of this document or the information contained herein.

Copyright © 2016 Natural Gas Fuel Systems, Inc. dba Momentum Fuel Technologies. All rights reserved.

ALL DIMENSION TOLERANCES UNLESS NOTED
ONE PLACE .X ±.06
TWO PLACES .XX ±.03
THREE PLACES .XXX ±.010
FOUR PLACES .XXXX ±.0010
ALL MACHINED SURFACES TO BE 250 RMS UNLESS NOTED.



DO NOT SCALE THIS PRINT

DRAWN brummern	2/15/2017	MOMENTUM FUEL TECHNOLOGIES 1051 Republic Drive, Suite 200 Roanoke, TX 76262		
CHECKED		TITLE HARNESS J1939 Y		
QA				
MFG				
APPROVED				
Part Mass		SIZE D	DWG NO MP92-1034	REV
		SCALE		SHEET 1 OF 2

8 7 6 5 4 3 2 1

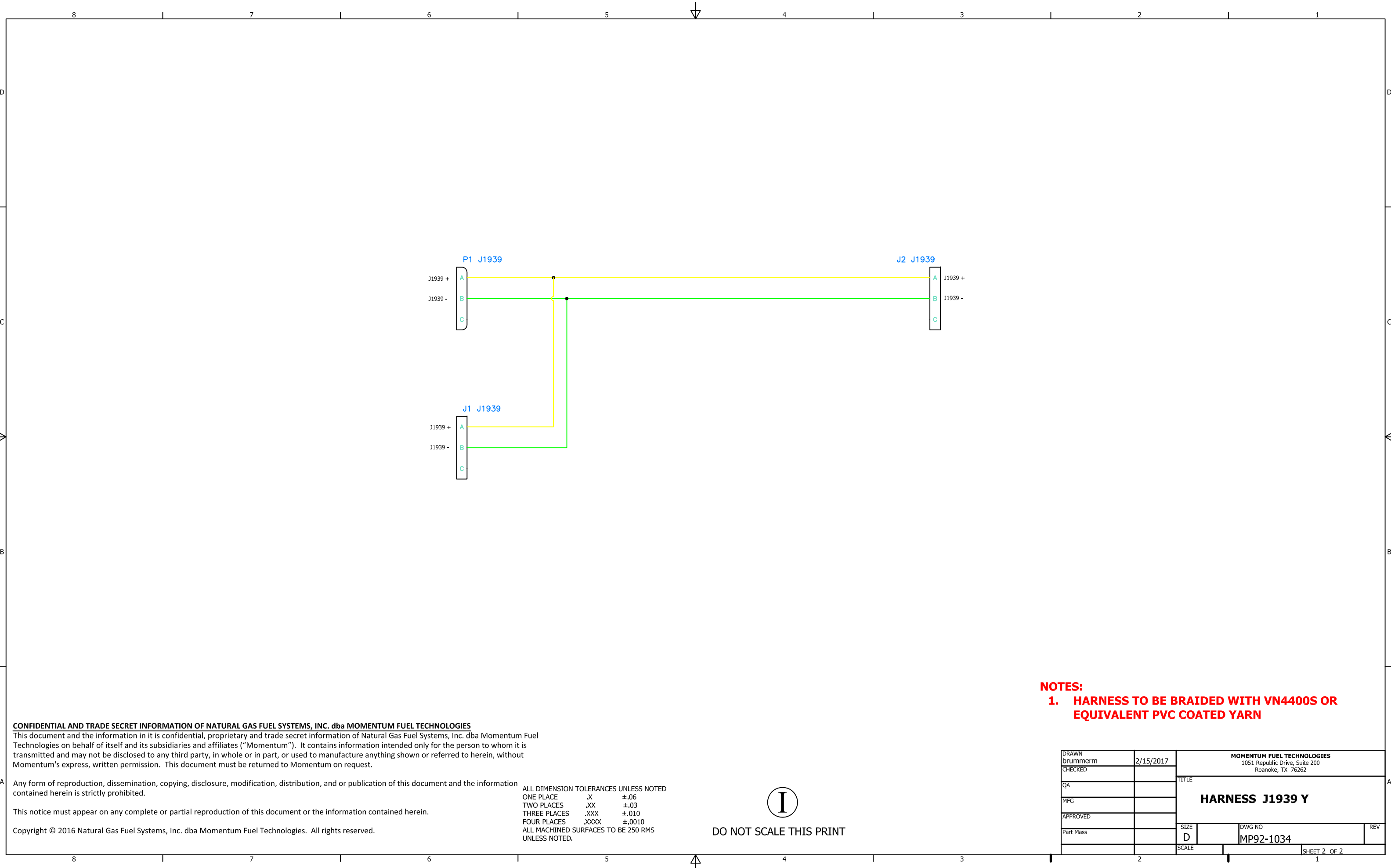

CONFIDENTIAL AND TRADE SECRET INFORMATION OF NATURAL GAS FUEL SYSTEMS, INC. dba MOMENTUM FUEL TECHNOLOGIES
 This document and the information in it is confidential, proprietary and trade secret information of Natural Gas Fuel Systems, Inc. dba Momentum Fuel Technologies on behalf of itself and its subsidiaries and affiliates ("Momentum"). It contains information intended only for the person to whom it is transmitted and may not be disclosed to any third party, in whole or in part, or used to manufacture anything shown or referred to herein, without Momentum's express, written permission. This document must be returned to Momentum on request.

Any form of reproduction, dissemination, copying, disclosure, modification, distribution, and or publication of this document and the information contained herein is strictly prohibited.

This notice must appear on any complete or partial reproduction of this document or the information contained herein.

Copyright © 2016 Natural Gas Fuel Systems, Inc. dba Momentum Fuel Technologies. All rights reserved.

ALL DIMENSION TOLERANCES UNLESS NOTED
 ONE PLACE .X ±.06
 TWO PLACES .XX ±.03
 THREE PLACES .XXX ±.010
 FOUR PLACES .XXXX ±.0010
 ALL MACHINED SURFACES TO BE 250 RMS UNLESS NOTED.



DO NOT SCALE THIS PRINT

NOTES:
 1. **HARNES TO BE BRAIDED WITH VN4400S OR EQUIVALENT PVC COATED YARN**

DRAWN brummerrm	2/15/2017	MOMENTUM FUEL TECHNOLOGIES 1051 Republic Drive, Suite 200 Roanoke, TX 76262	
CHECKED		TITLE HARNES J1939 Y	
QA		SIZE D	DWG NO MP92-1034
MFG		SCALE	REV
APPROVED			
Part Mass			
			SHEET 2 OF 2