

P2: FUEL SOLENOID
DEUTSCH DT06-2S

TERMINAL	WIRE	WIRE SIZE
1	BLU	18 AWG TXL
2	GRN	18 AWG TXL

J1: DOOR SENSOR
DEUTSCH DT04-3S

TERMINAL	WIRE	WIRE SIZE
C	RED	18 AWG TXL
A	BLK	18 AWG TXL
B	GRY	18 AWG TXL

P5: TRANSDUCER
DEUTSCH DT06-4S

TERMINAL	WIRE	WIRE SIZE
1	BLK	18 AWG TXL
2	RED	18 AWG TXL
3	BLU/WHT	18 AWG TXL
4	WHT	18 AWG TXL

P4: DIAGNOSTIC
DEUTSCH DT06-4S

TERMINAL	WIRE	WIRE SIZE
1	BLK	18 AWG TXL
2	RED	18 AWG TXL
3	DRN	18 AWG TXL
4	WHT	18 AWG TXL

J2: DIAGNOSTIC
DEUTSCH DT04-4P

TERMINAL	WIRE	WIRE SIZE
1		
2		
3	WHT	18 AWG TXL
4	WHT	18 AWG TXL

P3: DOOR SWITCH
RELAY
DELPHI 12065686

TERMINAL	WIRE	WIRE SIZE
30	YEL	18 AWG TXL
86	BLK	18 AWG TXL
85	GRA	18 AWG TXL
87A		
87	PRP	18 AWG TXL

P4: FMM CHASSIS
INTERFACE
DEUTSCH DT06-12SA

TERMINAL	WIRE	WIRE SIZE
1		
2	RED	18 AWG TXL
3	BLK	18 AWG TXL
4	DRN	18 AWG TXL
5	BLU/WHT	18 AWG TXL
6	GRY	18 AWG TXL
7		
8	BLU	18 AWG TXL
9	GRN	18 AWG TXL
10	YEL	18 AWG TXL
11	PRP	18 AWG TXL
12		

- NOTES:**
- HARNESS TO BE BRAIDED WITH VN4400S OR EQUIVALENT PVC COATED YARN**
 - USE WITH VERTICAL FMM BASIC BOX**
 - REPLACES MP92-1026, SWAPPED PINS 9 AND 10 ON CONNECTOR P4.**

CONFIDENTIAL AND TRADE SECRET INFORMATION OF NATURAL GAS FUEL SYSTEMS, INC.
This document and the information in it is confidential, proprietary and trade secret information of Natural Gas Fuel Systems, Inc. and its subsidiaries ("Natural Gas Fuel Systems"). It contains information intended only for the person to whom it is transmitted and may not be disclosed to any third party, in whole or in part, or used to manufacture anything shown or referred to herein, without Natural Gas Fuel System's express, written permission. This document must be returned to Natural Gas Fuel Systems on request.

Any form of reproduction, dissemination, copying, disclosure, modification, distribution and or publication of this document and the information contained herein is strictly prohibited.

This notice must appear on any complete or partial reproduction of this document or the information contained herein.

Copyright © 2016 Natural Gas Fuel Systems, Inc. All rights reserved.

ALL DIMENSION TOLERANCES UNLESS NOTED
 ONE PLACE .X ±.06
 TWO PLACES .XX ±.03
 THREE PLACES .XXX ±.010
 FOUR PLACES .XXXX ±.0010
 ALL MACHINED SURFACES TO BE 250 RMS UNLESS NOTED.



DO NOT SCALE THIS PRINT

DRAWN brummern	5/4/2017	MOMENTUM FUEL TECHNOLOGIES 1051 Republic Drive, Suite 200 Roanoke, TX 76262	
CHECKED CULBERSONC	5/4/2017		
QA		TITLE HARNESS-VERTICAL STAND ALONE FMM	
MFG			
APPROVED CULBERSONC	5/4/2017	SIZE D	DWG NO MP92-1037
Part Mass		SCALE	REV
		SHEET 1 OF 2	

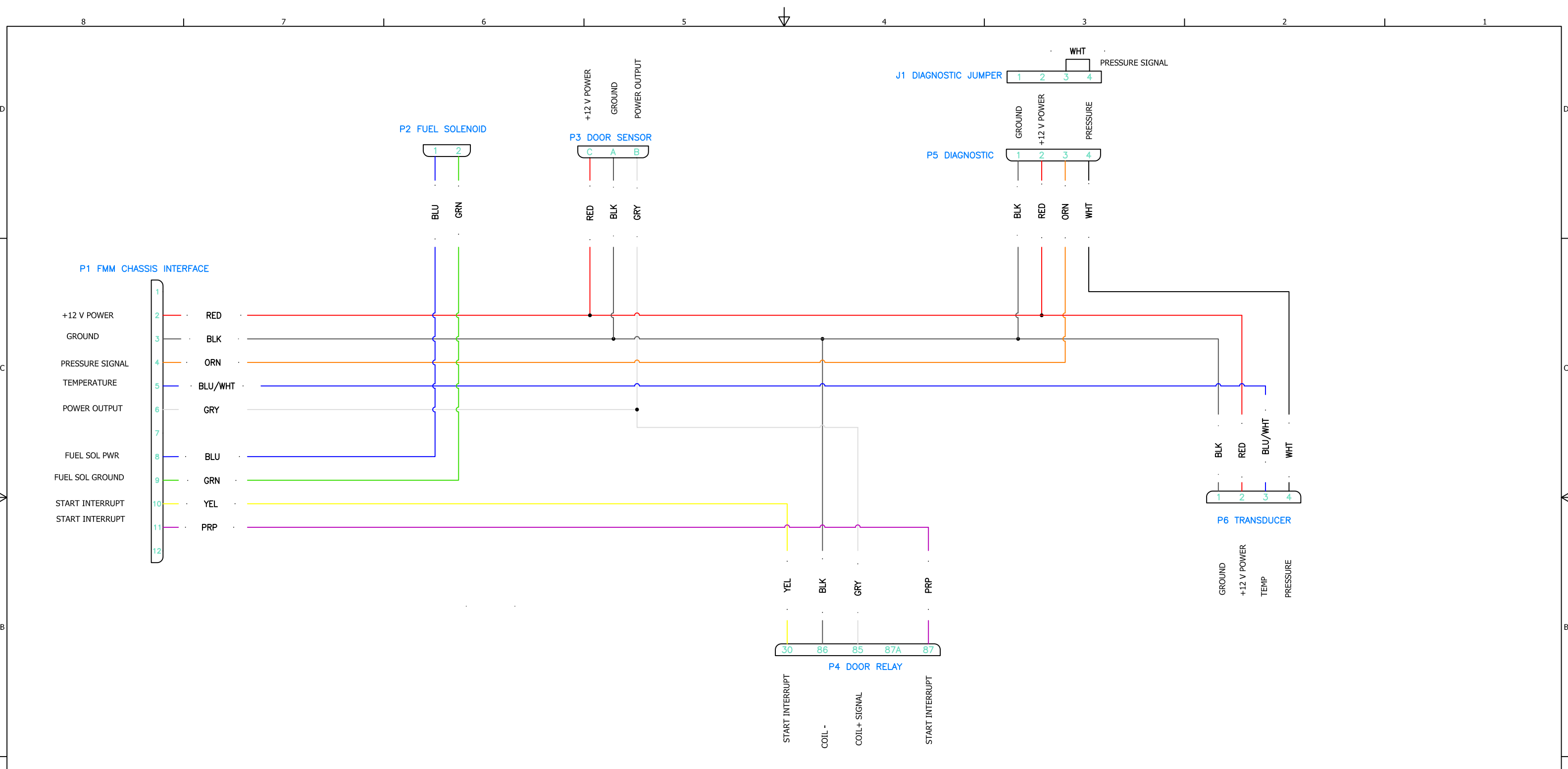

CONFIDENTIAL AND TRADE SECRET INFORMATION OF NATURAL GAS FUEL SYSTEMS, INC.

This document and the information in it is confidential, proprietary and trade secret information of Natural Gas Fuel Systems, Inc. and its subsidiaries ("Natural Gas Fuel Systems"). It contains information intended only for the person to whom it is transmitted and may not be disclosed to any third party, in whole or in part, or used to manufacture anything shown or referred to herein, without Natural Gas Fuel System's express, written permission. This document must be returned to Natural Gas Fuel Systems on request.

Any form of reproduction, dissemination, copying, disclosure, modification, distribution and or publication of this document and the information contained herein is strictly prohibited.

This notice must appear on any complete or partial reproduction of this document or the information contained herein.

Copyright © 2016 Natural Gas Fuel Systems, Inc. All rights reserved.

ALL DIMENSION TOLERANCES UNLESS NOTED
 ONE PLACE .X ±.06
 TWO PLACES .XX ±.03
 THREE PLACES .XXX ±.010
 FOUR PLACES .XXXX ±.0010
 ALL MACHINED SURFACES TO BE 250 RMS UNLESS NOTED.



DO NOT SCALE THIS PRINT

DRAWN brummerrm	5/4/2017	MOMENTUM FUEL TECHNOLOGIES 1051 Republic Drive, Suite 200 Roanoke, TX 76262	
CHECKED CULBERSONC	5/4/2017	TITLE HARNESS-VERTICAL STAND ALONE FMM	
QA		SIZE D	DWG NO MP92-1037
APPROVED CULBERSONC	5/4/2017	SCALE	REV
Part Mass			SHEET 2 OF 2