

J1 FUEL SENDER CHASSIS SIDE DELPHI 12129615		
TERMINAL	WIRE	WIRE SIZE
A	GRN	18 AWG TXL
B	YEL	18 AWG TXL
C	WHT	18 AWG TXL

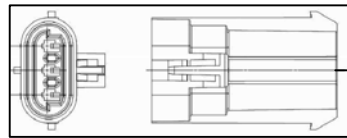

36"

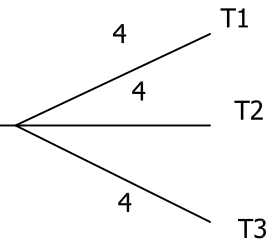

T1 FUEL SENDER WIRE DELPHI 12048074 WITH SEAL		
TERMINAL	WIRE COLOR	WIRE SIZE
T1	GRN	18 AWG TXL

T2 FUEL SENDER WIRE DELPHI 12048074 WITH SEAL		
TERMINAL	WIRE COLOR	WIRE SIZE
T2	YEL	18 AWG TXL

T3 FUEL SENDER WIRE DELPHI 12048074 WITH SEAL		
TERMINAL	WIRE COLOR	WIRE SIZE
T3	WHT	18 AWG TXL

P1 FUEL SENDER, SENDER SIDE  
DELPHI 12110293

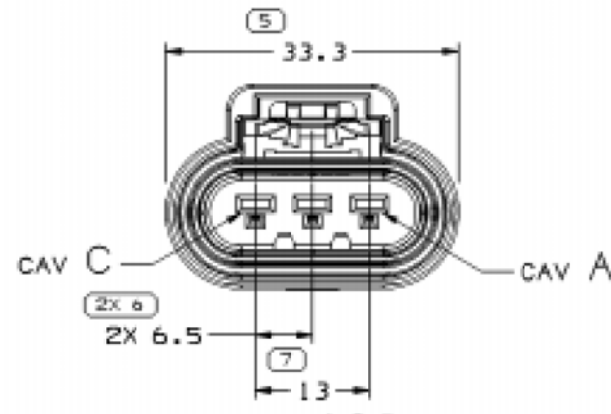

**NOTES:**

1. **HARNES TO COVERED WITH CONVOLUTED TUBING**
2. **USE WITH ISUZU TRUCK STRETCH**
3. **CRIMP TERMINAL ENDS AND SEALS T1, T2, AND T3**
4. **SHIP CONNECTOR P1 LOOSE IN BAG ATTACHED TO HARNES WITH SECONDARY LOCK**
5. **ALL WIRES TO BE SEALED IN CONNECTORS**

**CONFIDENTIAL AND TRADE SECRET INFORMATION OF NATURAL GAS FUEL SYSTEMS, INC. dba MOMENTUM FUEL TECHNOLOGIES**  
 This document and the information in it is confidential, proprietary and trade secret information of Natural Gas Fuel Systems, Inc. dba Momentum Fuel Technologies on behalf of itself and its subsidiaries and affiliates ("Momentum"). It contains information intended only for the person to whom it is transmitted and may not be disclosed to any third party, in whole or in part, or used to manufacture anything shown or referred to herein, without Momentum's express, written permission. This document must be returned to Momentum on request.

Any form of reproduction, dissemination, copying, disclosure, modification, distribution, and or publication of this document and the information contained herein is strictly prohibited.

This notice must appear on any complete or partial reproduction of this document or the information contained herein.

Copyright © 2016 Natural Gas Fuel Systems, Inc. dba Momentum Fuel Technologies. All rights reserved.

ALL DIMENSION TOLERANCES UNLESS NOTED  
 ONE PLACE .X ±.06  
 TWO PLACES .XX ±.03  
 THREE PLACES .XXX ±.010  
 FOUR PLACES .XXXX ±.0010  
 ALL MACHINED SURFACES TO BE 250 RMS UNLESS NOTED.



DO NOT SCALE THIS PRINT

DRAWN brummern	7/5/2018	<b>MOMENTUM FUEL TECHNOLOGIES</b> 1051 Republic Drive, Suite 200 Roanoke, TX 76262	
CHECKED CULBERSONC	7/19/18	TITLE	
QA		<b>HARNES- ISUZU FUEL SENDER EXTENSION</b>	
MFG		SIZE D	DWG NO MP92-1617
APPROVED CULBERSONC	7/19/18	SCALE	REV
Part Mass			
		SHEET 1 OF 2	

P1 FUEL SENDER, SENDER SIDE

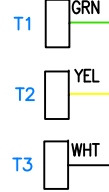

J1 FUEL SENDER, CHASSIS SIDE

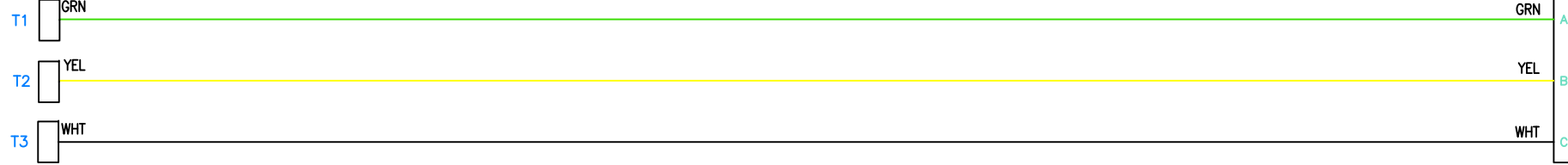
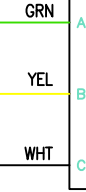

**NOTES:**

- 1. HARNESS TO COVERED WITH CONVOLUTED TUBING**
- 2. USE WITH ISUZU TRUCK STRETCH**
- 3. CRIMP TERMINAL AND SEAL ENDS ON T1, T2, T3**
- 4. SHIP CONNECTOR P1 LOOSE IN BAG ATTACHED TO HARNESS WITH SECONDARY LOCK**
- 5. ALL WIRES TO BE SEALED IN CONNECTORS**

**CONFIDENTIAL AND TRADE SECRET INFORMATION OF NATURAL GAS FUEL SYSTEMS, INC. dba MOMENTUM FUEL TECHNOLOGIES**

This document and the information in it is confidential, proprietary and trade secret information of Natural Gas Fuel Systems, Inc. dba Momentum Fuel Technologies on behalf of itself and its subsidiaries and affiliates ("Momentum"). It contains information intended only for the person to whom it is transmitted and may not be disclosed to any third party, in whole or in part, or used to manufacture anything shown or referred to herein, without Momentum's express, written permission. This document must be returned to Momentum on request.

Any form of reproduction, dissemination, copying, disclosure, modification, distribution, and or publication of this document and the information contained herein is strictly prohibited.

This notice must appear on any complete or partial reproduction of this document or the information contained herein.

Copyright © 2016 Natural Gas Fuel Systems, Inc. dba Momentum Fuel Technologies. All rights reserved.

ALL DIMENSION TOLERANCES UNLESS NOTED  
 ONE PLACE .X ±.06  
 TWO PLACES .XX ±.03  
 THREE PLACES .XXX ±.010  
 FOUR PLACES .XXXX ±.0010  
 ALL MACHINED SURFACES TO BE 250 RMS UNLESS NOTED.



DO NOT SCALE THIS PRINT

DRAWN brummern	7/5/2018	MOMENTUM FUEL TECHNOLOGIES 1051 Republic Drive, Suite 200 Roanoke, TX 76262	
CHECKED CULBERSONC	7/19/18	TITLE <b>HARNESS- ISUZU FUEL SENDER EXTENSION</b>	
QA		SIZE D	DWG NO MP92-1617
APPROVED CULBERSONC	7/19/18	SCALE	REV
Part Mass			SHEET 2 OF 2