

REVISION HISTORY				
ZONE	REV	DESCRIPTION	APPROVED	DATE
C6	A	ADDED 8" TO LENGTH OF J6		
C8	A	ADDED CONNECTOR P7		
D8	A	ADDED CONNECTOR J7		

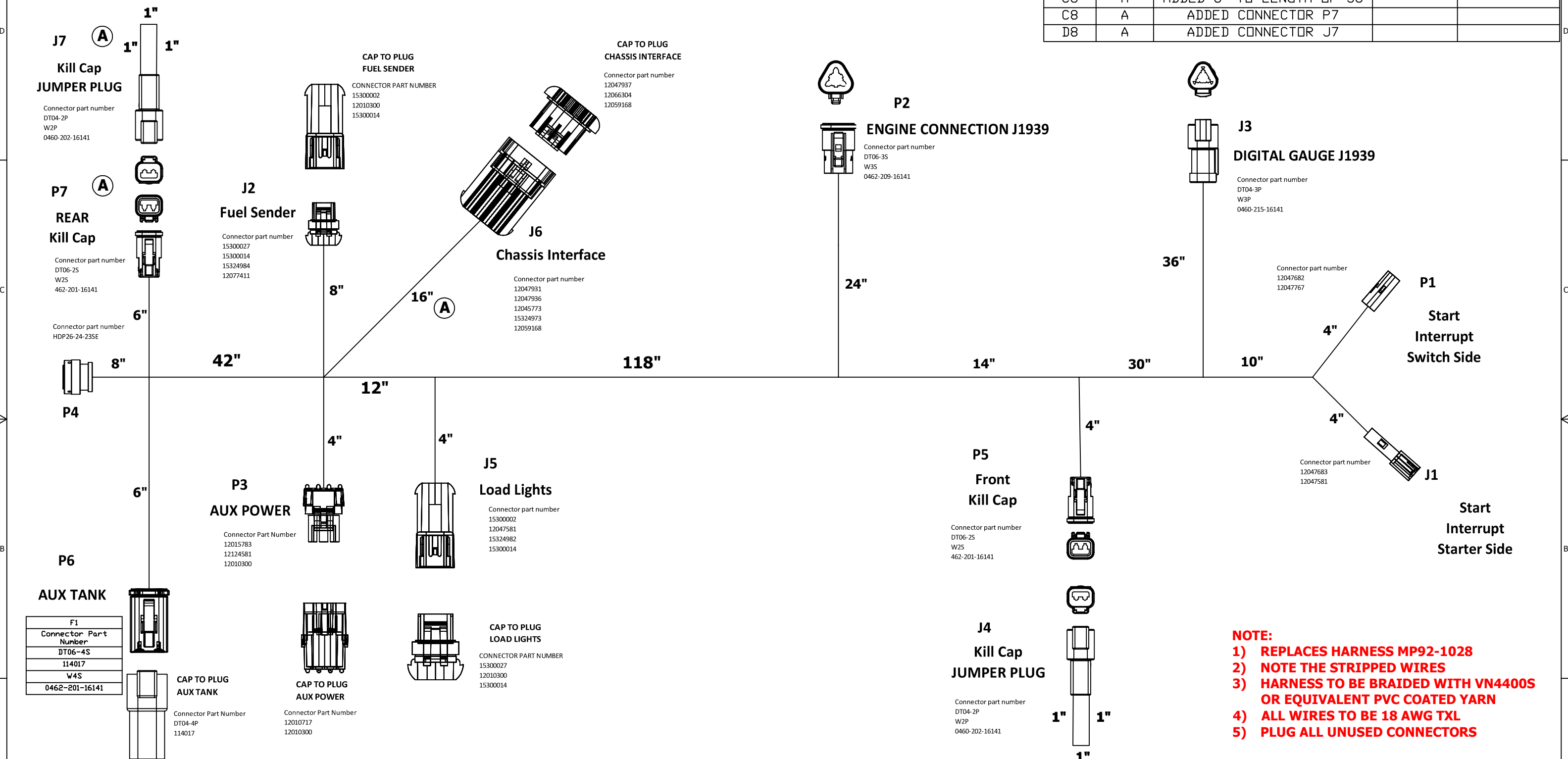

- NOTE:**
- 1) REPLACES HARNESS MP92-1028
  - 2) NOTE THE STRIPPED WIRES
  - 3) HARNESS TO BE BRAIDED WITH VN4400S OR EQUIVALENT PVC COATED YARN
  - 4) ALL WIRES TO BE 18 AWG TXL
  - 5) PLUG ALL UNUSED CONNECTORS

**CONFIDENTIAL AND TRADE SECRET INFORMATION OF RUSH ENTERPRISES, INC.**  
This document and the information in it is confidential, proprietary and trade secret information of Rush Enterprises, Inc. and its subsidiaries ("Rush"). It contains information intended only for the person to whom it is transmitted and may not be disclosed to any third party, in whole or in part, or used to manufacture anything shown or referred to herein, without Rush's express, written permission. This document must be returned to Rush on request.

Any form of reproduction, dissemination, copying, disclosure, modification, distribution and or publication of this document and the information contained herein is strictly prohibited.

This notice must appear on any complete or partial reproduction of this document or the information contained herein.

Copyright © 2014 Rush Enterprises, Inc. All rights reserved.

ALL DIMENSION TOLERANCES UNLESS NOTED  
ONE PLACE .X ±.06  
TWO PLACES .XX ±.03  
THREE PLACES .XXX ±.010  
FOUR PLACES .XXXX ±.0010  
ALL MACHINED SURFACES TO BE 250 RMS UNLESS NOTED.

**I**  
DO NOT SCALE THIS PRINT

DRAWN brummern	10/18/2019	MOMENTUM FUEL TECHNOLOGIES 1051 Republic Drive, Suite 200 Roanoke, TX 76262		
CHECKED culbersonc	10/19/2019	TITLE Harness-Chassis Interface, Peterbilt NGP Cab		
QA		SIZE D	DWG NO MP92-1634	REV A
MFG		SCALE		SHEET 1 OF 2
APPROVED culbersonc	10/19/2019			
Part Mass				

# REVISION HISTORY

ZONE	REV	DESCRIPTION	APPROVED	DATE
D3	A	ADDED CONNECTORS J7 & P7		
B8	A	ADDED PIN R		

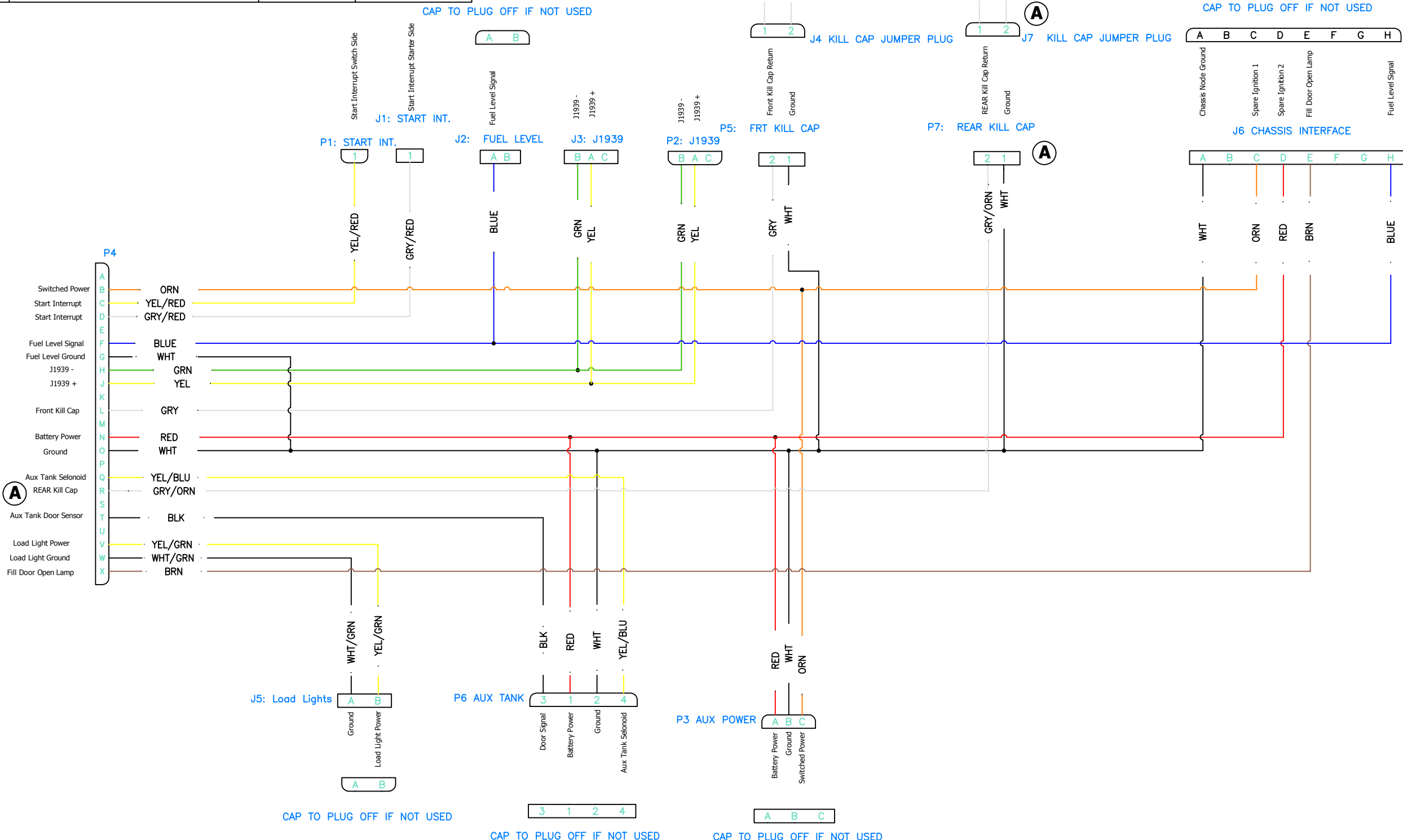

**CONFIDENTIAL AND TRADE SECRET INFORMATION OF RUSH ENTERPRISES, INC.**  
 This document and the information in it is confidential, proprietary and trade secret information of Rush Enterprises, Inc. and its subsidiaries ("Rush"). It contains information intended only for the person to whom it is transmitted and may not be disclosed to any third party, in whole or in part, or used to manufacture anything shown or referred to herein, without Rush's express, written permission. This document must be returned to Rush on request.

Any form of reproduction, dissemination, copying, disclosure, modification, distribution and or publication of this document and the information contained herein is strictly prohibited.

This notice must appear on any complete or partial reproduction of this document or the information contained herein.

Copyright © 2014 Rush Enterprises, Inc. All rights reserved.

ALL DIMENSION TOLERANCES UNLESS NOTED  
 ONE PLACE .X ±.06  
 TWO PLACES .XX ±.03  
 THREE PLACES .XXX ±.010  
 FOUR PLACES .XXXX ±.0010  
 ALL MACHINED SURFACES TO BE 250 RMS UNLESS NOTED.



DO NOT SCALE THIS PRINT

DRAWN brummerm	1/16/2017	MOMENTUM FUEL TECHNOLOGIES 1051 Republic Drive, Suite 200 Roanoke, TX 76262	
CHECKED CULBERSONC	2/13/2017	TITLE Harness-Chassis Interface, Peterbilt NGP Cab	
QA		SIZE D	DWG NO MP92-1634
MFG		SCALE	REV A
APPROVED CULBERSONC	2/13/2017	SHEET 2 OF 2	
Part Mass			